

FEBRUARY 2024

REDUCING PRODUCTION LINE WASTE

PAGE 8

ALSO IN THIS ISSUE

MERITS OF REPURPOSED EQUIPMENT 12

PACKAGING AND BATTERY LIABILITY 16

AND MORE!

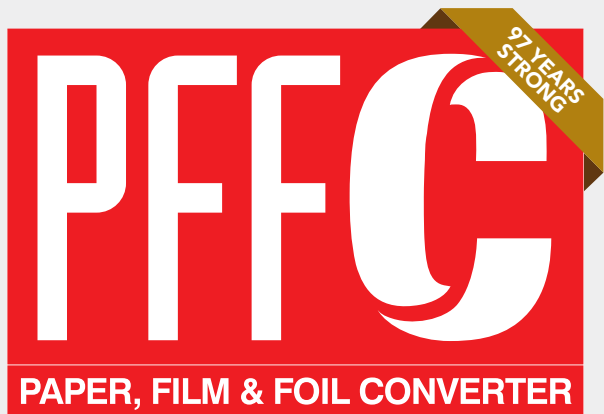

www.PFFC-Online.com

rdgmedia PUBLICATION

Need Roll-to-Roll Equipment?



Welcome to the future of increased production.

At New Era, we don't just manufacture equipment; we engineer productivity. Whether your needs are roll-to-roll equipment lines for battery materials or fuel cells; a coating or casting line for water filtration membranes; or simply a custom coating, laminating, or calendering line, our team is your secret weapon.

If you're ready to turbocharge your productivity with top-tier, US manufactured equipment, look no further. We're your trusted guides through the entire process, ensuring your success every step of the way.

For more information on New Era's groundbreaking systems, get in touch with us today via phone, email, or our user-friendly online portal.

It's time for a New Era in enhanced web handling productivity.



P. O. Box 377, Hawthorne, NJ 07507
Phone 201.670.4848

info@neweraconverting.com
neweraconverting.com



Powell Engineering, Inc. and MTorres join forces

for innovative solutions

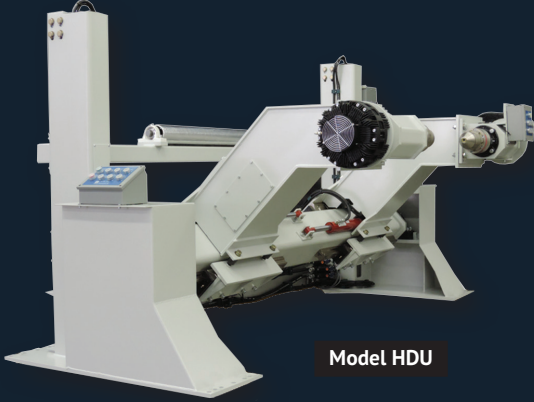

Model HDU



Model EP

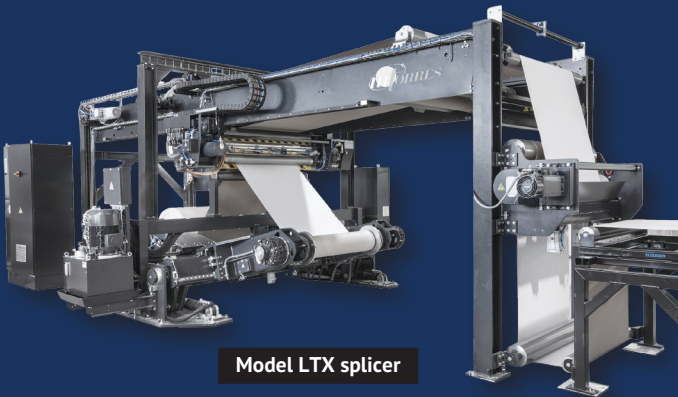

Model LTX splicer



TORRESWINDER

We are pleased to announce a strategic alliance between Powell Engineering, Inc. and MTorres, two leading firms serving the converting industries. The marketing alliance aims to leverage the expertise, resources and innovation of both companies to deliver a full range of solutions in the market segments served. The combined comprehensive machinery portfolio is set to expand options and solutions for North American customers.

With our shared commitment to excellence and customer satisfaction we are excited to share the news of our new joint project.



Phone: 205-625-5444 • 800-213-4267 • unwind@powellengineering.com

www.powellengineering.com

www.mtorres.com

Simplex Family

90s

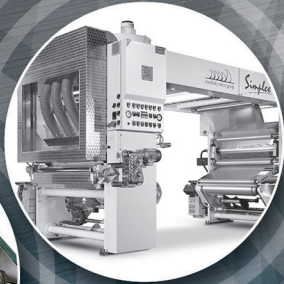

Super Combi Family

00s



Modular High Performance coater for High Speed Cold Form conversion

10s

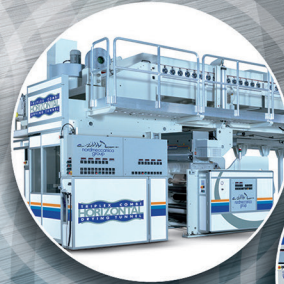

N-Gen

20s



Interchangeable coating heads on trolleys

80s

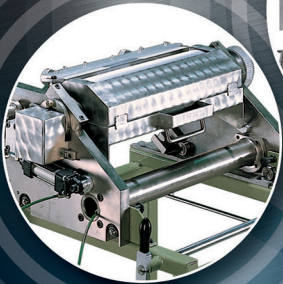

nordmeccanica group

Invented here, perfected here !

drupa

May 28 - June 7, 2024
Düsseldorf, Germany
www.drupa.com

no. 1 for printing technologies

2024

VISIT
nordmeccanica
HALL 15 - C40

Stay Tuned, things are coming.

Sustainability:

- Innovative High Barrier Structures.
- Recyclability enhancement.
- Energy saving and emission reduction.

Daily at Drupa live on stage.



COMPLETE REFURBISHMENT

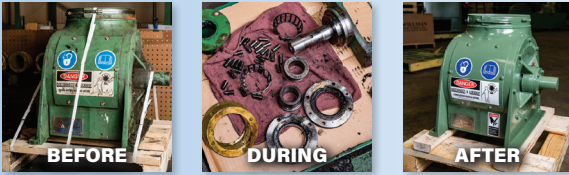

See Refurbishment tab at www.bloapco.com/trim-cutters or call 800-959-0880

TABLE OF CONTENTS

8 REDUCING WASTE IN THE
PRODUCTION LINE
Sustainable measures more important than ever.

12 THE MERITS OF A REPURPOSED
SLITTER WINDER
Certain goals become viable with rebuilt
equipment.

16 EXTINGUISHING LITHIUM-ION
BATTERY LIABILITY WITH GREEN
PACKAGING
Progress toward safe transport, storage and
recycling.

22 STICKING TO SUSTAINABILITY
WITH ULTRA-REMOVABLE LABELS
The advantages of micropheric adhesives.



DEPARTMENTS

6 EDITOR'S NOTE

18 STATIC BEAT
The importance of controlling
static stored on winding rolls.

26 PRODUCT & INDUSTRY NEWS

46 AD INDEX

Catbridge 900MC

The Hybrid Powerhouse

Combine the capabilities of a duplex center winder with the productivity gains of a turret.

Specifications:

- ✓ **Rewind diameter:** 32" (813 mm)
- ✓ **Web width:** up to 84" (2137 mm)
- ✓ **Web speed:** to 2500 fpm (763 m/min)
- ✓ **Minimum slit width:** 1" (25 mm)

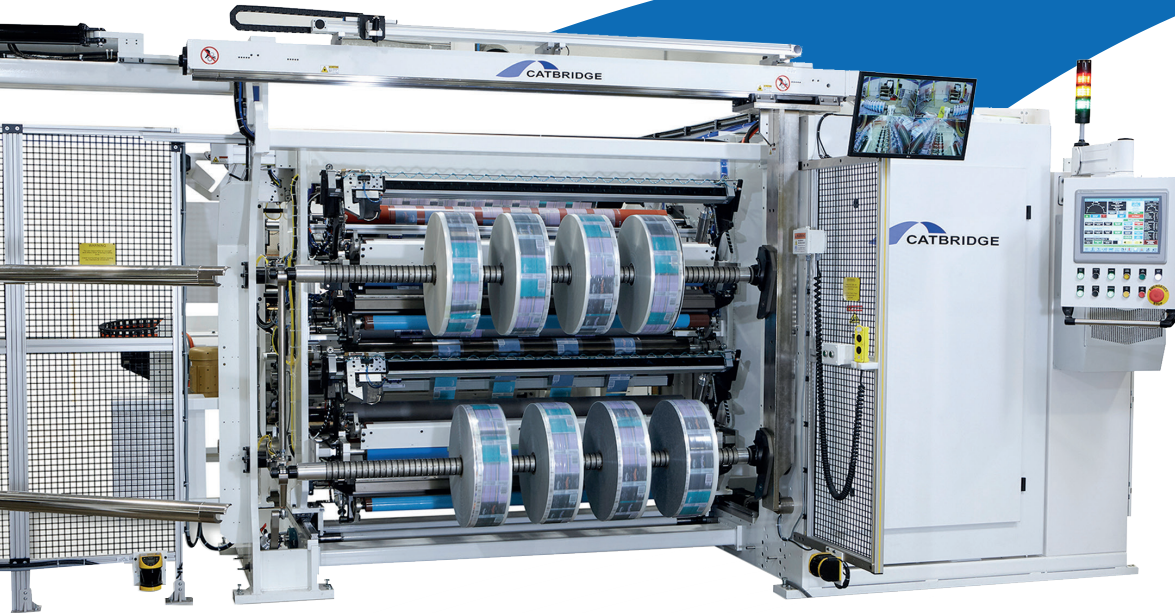

Material Mastery

Skillfully handles a diverse array of materials, from paper and primary films to flexible packaging laminations, pressure sensitives, and label stock.



Precision Cutoff Control

Features a strategically placed cutoff process near the rewind point for precise control of short strands, ensuring perfect roll alignment.



Versatility Rewind Capacity

Effortlessly rewinds up to a 32-inch diameter, ability to log wind with an additional lower lift-out feature.



Efficiency in Operation

Engineered with auto tabbing and auto cut and transfer technologies, significantly reducing downtime between sets.

Ready to elevate your converting operations?

Contact Catbridge today to explore how the 900MC can transform your converting operations. Learn more about this innovative solution and take the first step towards optimizing your process.



Out of the Shadows



Angel Morris
Editor

February may be the shortest month of the year, but its winter chill can make the days seem long. The month when all eyes turn to Punxsutawney Phil — the Pennsylvania groundhog whose shadow decides when we can expect spring — is also a good time to evaluate how our own efforts impact the environment.

In this month's cover story, *Reducing Waste in the Production Line*, the emphasis is on securing sustainable measures throughout all parts of production. Repurposing existing equipment is one way company's can meet goals such as increased

production and reliability while improving machine safety, which is the focus of the article, *The Merits of a Repurposed Slitter Rewinder*.

Battery safety is an ongoing topic of importance, and *Extinguishing Lithium-Ion Battery Liability with Green Packaging* analyzes how to safely transport, store and recycle these batteries in an eco-friendly way. *PFFC's* resident static expert, Kelly Robinson, speaks to the levels of static held by winding rolls (Spoiler alert: It's enough static to be harmful to humans!), while a guest contributor shares the advantages of ultra-removable labels for both companies and consumers.

Building on last edition, several businesses are featured as Leaders in Converting this month, with converting and packaging printing suppliers explaining how they go above and beyond for customers within their areas of expertise. With methods much more scientific than any groundhog, these industry masters can help you build on what you already know or start anew, regardless of when spring officially begins.

If you are an expert toward industry-advancing topics, *PFFC* would love to share your knowledge with its readers. Email us for more details!

Angel Morris
Editor-in-Chief
angelm@rdgmedia.net



A RDG Media, Inc. Publication
P.O. Box 529
Estero, FL 33929
586.227.9344
www.pffc-online.com

President/Group Publisher
Randy Green
randy@rdgmedia.net

Publisher
Lori Pisano
lori@rdgmedia.net
814.384.7813

Editor
Angel Morris
angelm@rdgmedia.net

Accounting Manager
Kristin Green

Systems Administrator
Angi Hiesterman

Operations/Customer Service
Jody Kirchoff

Web Design
Josh Scanlan

Auctions
Angi Hiesterman

Digital Marketing Specialist
Liz Bailey
lizb@rdgmedia.net

PFFC will not be responsible for any errors in placement or content after first run of ad. Publishers shall not be liable for any costs or damages if for any reason it fails to publish advertisement. PFFC recommends that you take appropriate caution before buying items sight unseen. PFFC is not responsible for misrepresentation of advertisers. We suggest you contact your own attorney, the Better Business Bureau, or appropriate government agencies if you experience a problem.

Randy Green, President & Group Publisher

Advertising rates, deadlines, and mechanical requirements furnished upon request. Copyright 2024 PFFC. All Rights Reserved. Reproduction in part or in whole without written consent is strictly prohibited.



ACCUDYNE TEST™ Marker Pens



- **22 Standard levels, from 30 through 72 dynes/cm**
- **Specifically designed for fast, accurate on-line use by printers, coaters, and laminators**

Also ideal for process control or field use by suppliers of film, sheet, coated board, inks, coatings, and adhesives

Spring loaded tip meters fluid feed and guards against contamination

Reliable enough for many R & D and lab applications

Hundreds of tests from each marker

Usable on virtually all smooth non-absorptive substrates

Six month shelf life; mix certifications provided with every order

Specify any combination of dyne levels and quantities you require (minimum order four pens)

Conveniently packaged in ready to use setup boxes

Total Qty.	Unit Price	Total Qty.	Unit Price
4-7	\$10.80	32-47	\$5.90
8-15	\$8.20	49-95	\$5.20
16-31	\$6.80	>96	\$4.80

Unit pricing is based on total order quantity. We now ship via ground service prepaid at no charge. Standard dyne levels include all even numbers from 30 through 72 dynes/cm. Free samples available on request.

Diversified Enterprises 101 Mulberry St., Ste 2N, Claremont, NH 03743
800-833-4644 or 603-543-0038; Fax 603-543-1334 www.accudynetest.com



CyClean-R incorporates advanced computational fluid dynamics that allow converters to thoroughly clean low-tension webs. Photos courtesy of Meech International.

Reducing Waste in the Production Line

By **Iain Cameron**, Marketing Director, Meech International

Sustainability remains a key talking point within the converting industry, and this makes it more important than ever that sustainable measures are put in place throughout all parts of the production line.

Static generation is one factor that can pose a significant threat on the quality of packaging while it is produced. If not dealt with correctly and eliminated, it results in nearby and airborne particles being attracted to the surface of a web, hindering the quality of the product, causing print work to potentially appear faded or dirty. Contamination by static on a web can even affect ink performance, repelling it away from the surface of a label.

Static can also pose a health and safety risk to staff. Static usu-

ally occurs when a web is moving at high speed. It occurs either via friction when the web makes contact with converting machinery, through “separation” – the unwinding of web rolls — or even via electricity from surrounding machinery.

A web can also become contaminated without the presence of static, when it is moving in high-speed as it drags along ambient air. This creates a boundary layer that can cause debris to become trapped within or beneath the surface of the layer.

Contaminated products, whatever the cause, can result in a high level of packaging products being rendered inadequate and having to be thrown away, affecting the overall production line, increasing waste and slowing

down productivity.

Fortunately, highly sophisticated static control and cleaning equipment is available that can counter static charges and contamination, ensuring productivity remains at an optimal level.

Web Cleaning

Web cleaners act to effectively resolve contamination issues. Available in two forms, they are highly efficient at removing loose, dry debris from the web’s surface.

Web cleaning technology comes in two forms — contact and non-contact. Contact web cleaners are suitable for the narrow web label market. Designed to make contact with the web and break through the boundary layer, they typically use an elastomer and

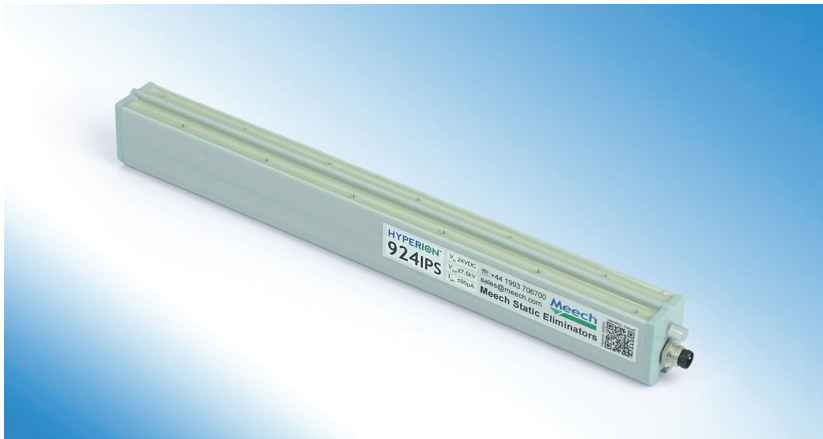

Powered by 24V DC, the Hyperion 924IPS is the most compact pulsed DC bar available on the market.



SmartControl Touch allows the user to remotely monitor, control and adjust the performance of multiple connected Hyperion ionizing bars and sensors.

adhesive roller based system, making them ideal for the removal of small particles (as low as 0.5 micron). Other contact systems utilize steel faceplates and brushes to break the boundary layer, although these are less suitable for sensitive substrates.

Non-contact systems have been designed in response to increased demand for compact, high-performance, non-contact web cleaning. These machines typically remove and extract

contamination to below 1 micron. Able to clean both sides of the web, they strip the boundary layer of contaminants, capturing them in the airstream and vacuuming them away. Such systems may use positive and negative airflows to break the boundary layer and vacuum away the contamination.

Other forms of non-contact web cleaners use high-velocity rollers, which are typically placed within 1mm of the surface of the web. The roller generates a high-

speed boundary layer of air. The greater energy of which destroys the boundary layer associated with the incoming web, exposing even the smallest particles to the powerful cleaning force.

Customers should be aware that deciding on the most practical system depends on the web materials being processed, the application, the flexibility required by the converting line and the available budget. While web cleaners can help deter issues surrounding product quality and staff safety, these devices alone will not solve all problems associated with a statically charged web and are most effective when worked in tandem with static control devices.

Static Control

Though web cleaners are very effective at removing contamination, the most effective way to prevent it is to incorporate static control, which can neutralize the charge. This is achieved via the use of an active static control device, such as a DC ionizing bar, which is typically placed before a web cleaner on a production line. It directs positive and negative ions of electricity at the web's surface, neutralizing any charges present.

Most modern ionization bars are available in a range of formats that suit short, medium and long-range applications. Compact in size, these bars are easy to install and with a 15KV pulsed DC output, their performance is unmatched.

With Industry 4.0 becoming a more prevalent topic within the technology world, static control devices are starting to incorporate automated features. These enable operators to see the performance



TakClean Ultra is an advancement of Meech's TakClean™ system and has been manufactured specifically for webs between 650 and 1,450mm in width.

as possible, with minimum waste. It reduces waste on the production line, to ultimately avoid increasing carbon footprints and damaging reputation. It is also important to remember that there is not a one-size-fits-all approach. Instead, you must seek a tailor-made solution, ideal for your business. ■

ABOUT THE AUTHOR

Iain Cameron oversees marketing for Meech International, the UK-headquartered, world-leading manufacturer of Static Control Equipment, Web Cleaning Systems and energy efficient Compressed Air Technology. Meech products are used extensively in a wide range of industries including Packaging, Printing, Converting, Plastics, Food and Drink, Automotive and Pharmaceutical.

information of the static control device and control it via a local user-friendly display, such as a mobile phone, tablet, touch screen or monitor. These devices can also be connected to static bar controllers, which alter the level of ionization supplied from the static bar.

Taking Action

As sustainability remains a growing trend within the industry, web cleaning and static control equipment are must-haves for label and packaging manufacturers to ensure production lines run as effectively

The name in Safety Chucks.

Since 1980, Boschert has been proud to provide standard and customizable safety chuck solutions to the converting industry. Now, we're offering even more products to meet your needs, encompassing brakes, clutches, aluminum cones, and more.

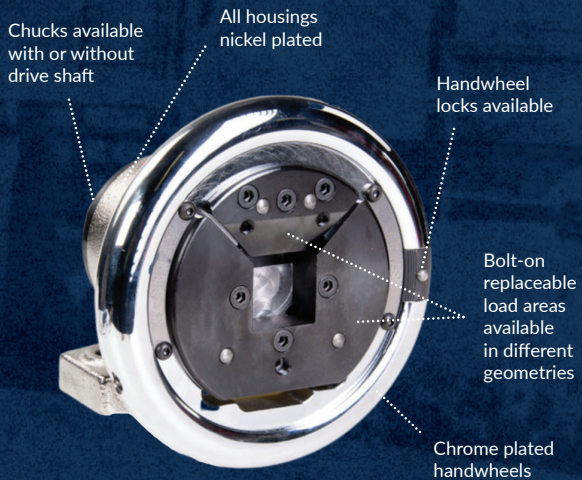

800.479.0010

boschertllc.com

BOSCHERT
SAFETY CHUCK SPECIALISTS



**SONIC
SOLUTIONS™**

BIG

System that can clean sleeves up to 70" long

or

SMALL....

System that cleans
narrow and medium
web rolls



...we can clean them all!

**All our anilox roll and sleeve
cleaning systems reflect:**

- Preset functions that allow you to safely clean the highest line count anilox.
- Plug and play external power generators that can be easily replaced
- Stainless steel construction for longest durability
- Over 20 years of proven industry experience
- Fast friendly service that only a family run business can provide

Call or e-mail us for more information

877.654.7800

customer_service@sonicsolutionsusa.com

www.SonicSolutionsUSA.com



SONICKLEEN

**Sonic Kleen - The original and
still the best.**

The Merits of a Repurposed Slitter Rewinder

By **Alan Fayerman**, Product Manager and **Bill Strake**, Sales Manager, Valmet

When a converter approaches an OEM supplier with a need for a slitter rewinder, project goals and scope must be conveyed precisely and clearly. Project intents typically fall in one of the following four areas: Increased production, improved finished roll quality, increased reliability and improved machine safety. With these goals in mind, consideration should be given to the possibility of rebuilding the existing equipment.

Existing equipment may need to be repurposed for running new products. For example, a slitter rewinder may have been originally designed for running a nonwoven product and now needs to be reconfigured to run a lightweight grade paper. This conversion may require alternate slitting modes where the score slit system is replaced with a shear system (be it tangential or wrap shear) or remain in place where both systems are needed.

Increased Production Needs

If the project goal is increased production, beyond faster winder speeds, material handling efficiency should be examined to find ways to reduce the machine downtime during roll set changes and decrease slitter set up times. Increased production can often be achieved by providing a pickup unwind (either shafted or shaftless) that will replace an old style shafted backstand. Conversely, shaftless rewinding, or cantilever rewind shafts, can eliminate the need for rewind shaft handling.

Winder downtime can be decreased by adding roll cut-off knives, finished roll discharge devices and core insertion mechanisms. These items include roll cradles, ejectors, pushers and roll manipulators, all of which must be customized to the downstream finishing process.

Core and finished roll taping, and if required for the product, tabbing insertion, are also available to increase winder throughput.

Replacing older drum and water-cooled brakes with modern braking systems will reduce operating cost and usually supply a greater range of tension control.

At the same time, rewind shaft handling equipment along with automated hoist systems will reduce winder downtime.

If the product maker line can supply larger finished rolls that will be sent to the slitter,



When deciding to upgrade a machine, it's critical to partner with a supplier that understands the existing equipment to ensure minimal downtime. Photo courtesy of Valmet.

manufacturers can realize reduced change over time by making multiple finished sets from a single master roll.

Quality Improvements

Finished roll quality improvements can often be addressed by automatically controlling web tension, nip load and the torque output of the winder drive system. Higher winder speeds often require faster control reaction times where an electronic tension control system might replace an older mechanical dancer roll.

Replacing worn components is a typical way to bring a slitter rewinder back to peak operating condition. For example, worn winding drums can contribute to

Increased production can often be achieved by providing a pickup unwind (either shafted or shaftless) that will replace an old style shafted backstand. Conversely, shaftless rewinding, or cantilever rewind shafts, can eliminate the need for rewind shaft handling.

several winding defects including dishing, interweaving, loose starts, telescoping and inconsistent roll density.

Converters can attain improvements in slit web separation by replacing bow spreader bars with bowed rolls. While spreader bars still have a place in the converting industry, modern web coatings may be susceptible to picking and surface scratching. These web defects can sometimes be eliminated with the use of a bow spreader roll.

Improved Reliability

Historically, converting winders have been driven by variable speed DC drives and motors. However, in recent years, DC motors and drives have been replaced by AC vector drives and motors. The reason being, AC motors tend to require less

SmartControl™ Touch

Take charge of your static control

Remote Monitoring & Adjustment

Achieve optimum static control on your production line at all times.

Central Control

Monitor the performance of up to 30 ionizers without stepping foot on the factory floor.

Fast & Accessible

Access data for your static control equipment using the 10" touchscreen, or on your desktop or mobile.

✉ info@meech.com

☎ +1 (330) 564 2000

🌐 www.meech.com



- Improved quality
- Reduced wastage
- Less downtime
- Higher efficiency

maintenance, and are less costly to purchase and operate.

Improved Safety

Machine guarding has become an area of concern for the converting industry. When safety is a project driver, the overall mechanical condition and configuration of the machine must be reviewed to ensure that the required safety equipment can be physically added. These devices might include safety latches that retain roll cradles or other moving equipment. Additional components, such as safety mats and fencing, photo eyes and appropriately placed emergency stop devices may be required as well.

Often, spacing between driven and non-driven rolls, as well as stationary machine structures, may not provide the proper safe clearance distances. Adapting physical guarding and safety upgrades to an older winder may sometimes impact winder capacity. These losses are often offset with additional automation upgrades.

Another pain point converters often have is the need for an existing piece of equipment to operate with speeds exceeding the original design parameters. Increasing operating speeds, as well as the winder's level of safety, may require components which may not physically fit within the confines of the existing winder or be cost prohibitive. When faced with this

scenario, the only real solution is to build a new winder where all the functionality, production needs and current safety requirements are provided as a standard.

Partnering with the Right Supplier

When looking to upgrade a machine, whether the goal is improved quality, reliability, safety or production levels, it is important to partner with a supplier that can help identify the existing equipment that can be remanufactured and repurposed for a current need. Some suppliers can offer rebuilds with minimal downtime, and depending on the scope of the rebuild, provide a new machine warranty. ■



Northcore
INDUSTRIES

Family-Owned Global
Supplier of Plastic Cores

CALL 608 355 2898 EMAIL info@northcoreind.com EXPLORE northcoreind.com

ISO 9001

ABOUT THE AUTHOR

Bill Strake has been associated with the Cameron product line since 1983 as Business Development and Regional Sales Manager. When the Cameron and GLV brands were acquired by Valmet in 2019, Bill became a Cameron consultant for Valmet. Bill holds a Bachelor of Science degree from Roger Williams University in Bristol, RI and is an active member of the Technical Association of the Pulp & Paper Industry.

Alan Fayerman has over 40 years experience in the paper and converting industry, beginning his career with the Cameron product line in 1983. He has held various roles including Applications Engineer, Mechanical Engineering Manager, VP of Engineering and President at Cameron in the U.S. When the Cameron and GLV brands were acquired by Valmet in 2019, Alan became Product Manager for Specialty Winders. He has a Bachelor of Science in Mechanical Engineering from the New Jersey Institute of Technology and a Master of Business Administration from Seton Hall University.

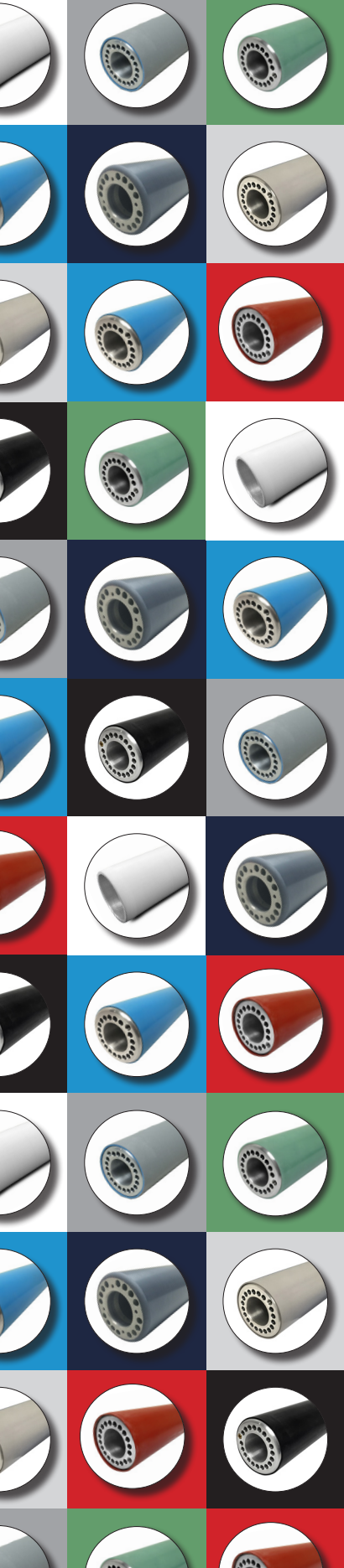

Corona Treating. High Release. Web Cleaning. Traction. Anti-Static.

**Jemmco has you (and
your rollers) covered.**

Your trusted roller covering provider since 1999.
Silicone Stretch Sleeves • Heat Shrink Sleeves • Ceramic •
Epoxy • Bonded Rubber • Thermal Spray Coatings • & More!

Jemmco, LLC

CALL TODAY TO SPEAK WITH A PRODUCT SPECIALIST!
262-512-9559 • sales@jemmco.com
www.jemmco.com

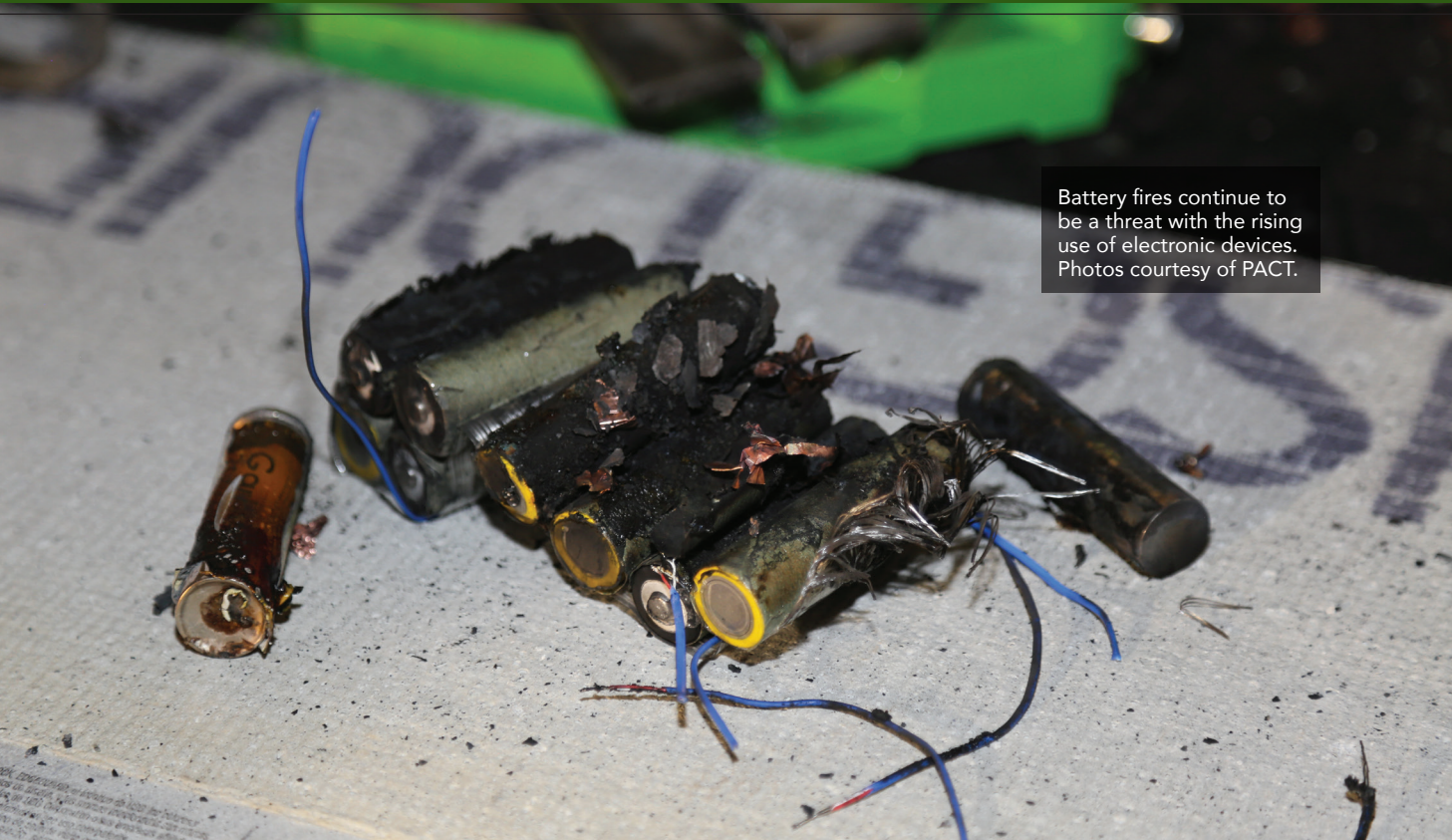

Battery fires continue to be a threat with the rising use of electronic devices. Photos courtesy of PACT.

Extinguishing Lithium-Ion Battery Liability with Green Packaging

By **Rodger Mort**, President, Packaging and Crating Technologies (PACT®), LLC

Despite the dangers, lithium-ion batteries are here to stay. How to safely transport, store and recycle these batteries that are used to power hand-held electronics, e-bikes, scooters and more was a hot topic at the recent Battery Show in Michigan.

Shipping lithium-ion batteries can be hazardous. One of the biggest threats is battery explosion that leads to thermal runaway – a phenomenon in which the lithium-ion cell enters an uncontrollable, self-heating state caused by extremely high temperatures, shaking or puncturing. The resulting flames are extremely difficult for firefighters to extinguish, so the fires usually have to smolder

out on their own after many hours, emitting lethal fumes and gases.

To avoid potential loss of life or property damage from these fires, the first step is to use outer packaging made of durable, waterproof and cushioned, yet cost-effective and eco-friendly, materials. Keep purchasing and shipping costs down with packaging that is also lightweight and reusable. Good options are UN-rated fiberboard containers and UN-rated wooden crating.

To ensure safety and avoid compliance issues, companies also need to adhere to the U.S. Department of Transportation (DOT) standards that make sure lithium cells and batteries shipments are

properly packaged to be able to withstand normal transportation conditions.

The next step is to wrap these batteries in a protective material that can contain both fire and residual smoke, such as a lightweight, paper material with a moisture vapor application that prevents thermal runaway. However, if thermal runaway does occur, such wraps immediately cool the internal environment of the package, while limiting oxygen around the payload. There are such solutions that not only meet, but exceed the proposed SAE G-27 standards for safety in shipping lithium-ion batteries via land, sea and air.

An added concern is transporting batteries, as well as lithium-ion powered devices that are damaged or recalled. With this technology, PACT received a special permit from the DOT to ship damaged lithium batteries safely and effectively, and many customers have been able to ship DDR and recyclable batteries at a lower cost.

Recently, the items containing lithium-ion batteries that have ignited dangerous fires are electric bikes, scooters, hoverboards, unicycles and electric cars. To address this escalating issue, a specially-coated, fire-suppressant paper wrapped around each battery cell to mitigate thermal runaway between them — thus serving as a heat and flame barrier — is recommended. Independent, third-party organizations have tested some such products multiple times and concluded that they prevented thermal runaway propagation amongst cells. To safely transport and store recyclable smaller devices such as cell phones, pagers, smartwatches and A-D batteries, a similar but smaller product exists.

In the event of a lithium-ion battery fire, water alone will not put out the flames. There is a new product offering a pre-mixed, water-based solution that quenches fires upwards of 1600 F within 30 seconds, while eliminating the release of toxic gases into the environment. When sprayed from an automatic or manual nozzle, the solution sticks to 3-D shapes, overhead and vertical surfaces, and easily penetrates small crevices. Further, it is designed to be used without personal protective equipment (PPE) and its powder-like residue is safe to wash



Durable, waterproof and cushioned outer packaging for batteries can still be cost-effective and eco-friendly.

and flush into sewers. The extinguisher successfully passed all burn tests conducted by VTEC Laboratories in New York City, the recommended lab by the Fire Department of New York.

In conclusion, as the number of electronic devices continues to increase in our modern society, so does the threat of deadly lithium-ion battery fires which power them up. We must continue to bring together engineers, business leaders, top-industry companies and innovative thinkers to discover ground-breaking products and create powerful E-mobility battery solutions for the future. ■

ABOUT THE AUTHOR

Rodger Mort is Chief Operating Officer at PACT, a global manufacturer of sustainable, corrugated cardboard packaging containers for the commercial, industrial and military industries. Mort brings 38 years of green packaging experience to the industry with a specialty of designing paper-based packaging material that suppresses and controls lithium-ion battery fires by mitigating thermal runaway. Under his direction, the company is a current member of the Commercial Relocation Network, the Council on Safe Transportation of Hazardous Materials and the International Association of Movers. Visit www.pactww.com for more information.

ANTI-STATIC SOLUTIONS

Long-Range Anti-Static Bars • Tinsel • Anti-Static Cord • Anti-Static Stretch & Heat Shrink Roller Sleeves



Jemmco, LLC 262-512-9559 • sales@jemmco.com • jemmco.com

Does Winding Generate Static?

Static levels can build on a winding roll even when the entering web is “neutral”

By Dr. Kelly Robinson, Founder, Electrostatic Answers

A winding roll can store a lot of static charge. A winding roll can store enough static charge to threaten human health. Once as I began to measure the static level on a winding roll, I was shocked by a spark that was about 20 inches long. This shock was painful and damaged my electrostatic fieldmeter. Controlling static on winding rolls is both to protect operators from dangerous shocks and to protect products that may be damaged by static sparks.

Even a little bit of static charge on the entering web in Figure 1 can cause in high static on the winding roll. Reading E_{web} on the entering web responds to all the charges inside control volume CV_{web} . The reading of +5 kV/in shows that there is just a small amount of positive static on the entering web. Reading E_{roll} responds to all the

charges in control volume CV_{roll} , which extends into the winding roll. The reading of +50 kV/in, which is very high, shows that there are many charges inside the control volume.

A winding roll can store a long length web. For example, when winding a 2 mil (50 μ m) thick web on a 4-inch diameter core, a 20-inch (~0.5 meter) diameter winding roll stores web length of about 12,000 feet (3,700 meters). The winding roll also stores all the charge on this length of web. Even a small amount of static charge per foot on the entering web can cause a large amount of static on the winding roll.

Even though the entering web in Figure 2 is charge neutral, it can cause in high static levels on the winding roll. The entering web has balanced charges where

one surface has positive charges, and the other surface has an equal number of negative charges. Reading E_{web} responds to all the charges inside control volume CV_{web} . While there may be a lot of static charges inside CV_{web} , there are equal numbers of positive and negative charges. So, the fieldmeter displays 0 kV/in meaning that the web is charge neutral.

As the web winds onto the winding roll, the positive charges on the top surface of the web wind onto the outside of the roll. As the winding roll turns, these positive charges enter the winding nip. If the charge density is uniform down the length of the web, for every positive charge on the outside surface of the winding roll that enters the winding nip, there is a negative charge on the bottom surface of the entering web. So, the volume of the winding roll is approximately neutral. Reading E_{roll} , which responds to all the charges inside control volume CV_{roll} reads +25 kV/in indicating that there are many positive charges on the outside surface of the winding roll.

Balanced charges are very persistent. Powered static bars and passive dissipaters cannot neutralize balanced charges because these devices respond just like fieldmeters. Since there are an equal number of positive and negative

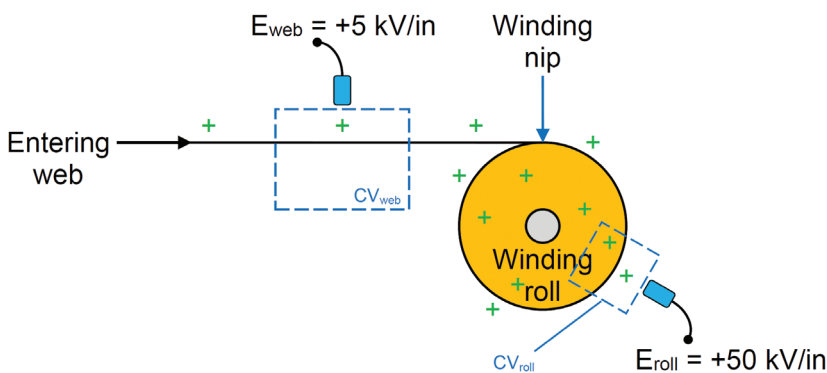

Figure 1 A winding roll can store a large amount of static charge.



TLMI

COMMUNITY. INSIGHT. ADVOCACY.

Take your company to the NEXT level with TLMI.

For 90 years, TLMI has evolved with the ever-changing industry because...

WE INVEST IN THE FUTURE OF OUR INDUSTRY...

The TLMI's Label Leaders of Tomorrow is a group of the young and young at heart within TLMI gathering, growing and sharing ideas for the betterment of the label industry and their own personal/professional development.

WE ARE LED BY OUR MEMBERS...

TLMI Committees are led by Members and drive initiatives that align to TLMI Strategic Priorities and Values. Employees of member companies can join any committee, which include Membership, Regulatory Affairs, Sustainability, Technical, and Workforce Development.

WE HOST THE INDUSTRY'S TOP EVENTS...

Each year TLMI hosts three in person events across the country where members learn about industry trends, participate in panel discussions and peer groups, and create connections with other industry leaders.

THE FACTS



SCAN TO JOIN TLMI!

98%

event satisfaction

65%

label industry sales revenue attributed to TLMI members

90

TLMI is celebrating it's 90th anniversary this year



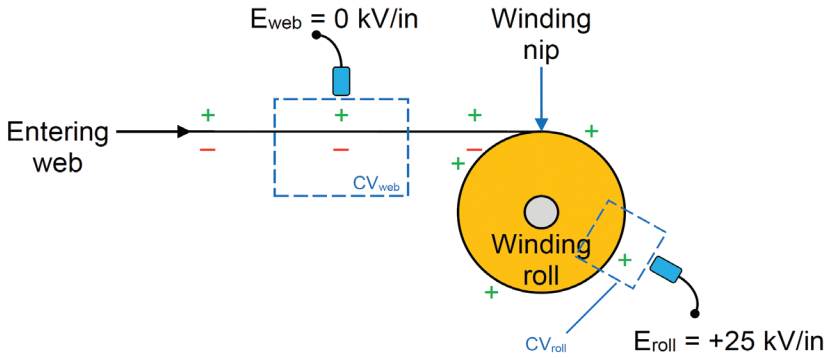

Figure 2 Balanced charges on the entering web cause high static levels on the winding roll.

charges on the web, a static dissipater sees the web as “neutral” and contributes no neutralizing ions. Similarly, balanced charges persist through coating operations. Depositing a layer of conducting liquid on one surface of the web does not change the charges on

the other surface. So, the balanced charges persist through coating.

To determine if balanced charges are causing high static levels on the winding roll, take readings E_{web} and E_{roll} shown in Figure 1 and Figure 2. Note the polarity of the readings. If the

polarities are different, then the entering web has balanced charges.

If E_{roll} is large (greater than $\pm 15 \text{ kV/in}$) and E_{web} is nearly zero (less than $\pm 2 \text{ kV/in}$), then the entering web very likely has balanced charges.

Solve this problem by practicing good static control upstream of the winding roll. Balanced charges are usually caused by installing a static dissipater on the wrong side of the web. In Figure 3, the entering web has negative static charges on the bottom surface perhaps from touching a rubber nip roller or other source of static charging. The powered static dissipater, facing the uncharged, top surface, responds to all the static charges inside control volume CV_{web} . The static dissipater deposits



Custom Converting Equipment

EQUIPMENT

- Unwind / Rewinds
- Accumulators
- Slitters / Laminators
- Traverse / Spiral Winders
- Festooners
- Inspection Equipment
- Lab / Pilot Extrusion Lines

MARKETS

- Filtration
- Medical
- Textile
- Packaging
- Hygiene
- Automotive
- Extrusion
- GeoTextile / Industrial Fabrics

We employ our 70 years of web handling experience to benefit our customers. Contact Chase Machine today for your equipment needs!
www.chasemachine.com

324 Washington St., West Warwick, RI USA 02893
401.821.8879 • Sales@chasemachine.com
www.chasemachine.com



Ultrasonic Laminators



Unwinds / Rewinds



Custom Assembly Equipment

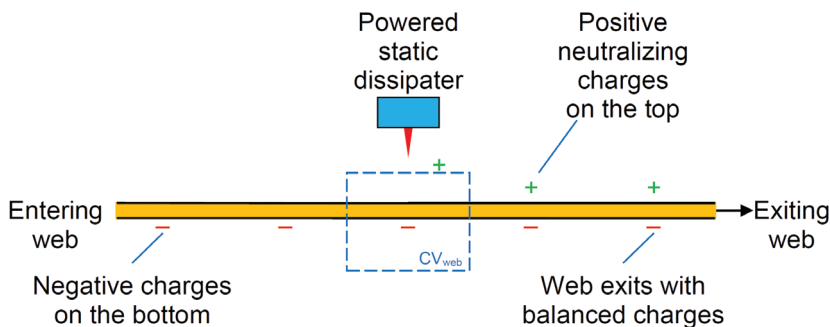

Figure 3 The static dissipater deposits a positive neutralizing charge for each negative charge on the bottom of the web.

one positive, neutralizing charge on the top surface for each negative charge on the bottom surface.

The exiting web has one positive neutralizing charge on the top surface for each negative charge on the bottom surface. The charges on the bottom surface of the web are

not changed by the static dissipater because the dissipater faces the other surface.

Fix this problem simply by moving the powered static dissipater so that it faces the bottom, charged surface.

Winding rolls can store large

amounts of charge even when the entering web is “neutral.” To see if balanced charges are causing high static on a winding roll, measure the static level on the web entering the winding roll and on the winding roll. Solve this problem by practicing good static control upstream of the winding roll. ■

ABOUT THE AUTHOR

Dr. Kelly Robinson writes on static issues occurring in converting processes. Robinson founded Electrostatic Answers, has 40-plus years experience in industrial problem solving and was named Top Manufacturing Consulting Services Provider 2023 by Managing MFG. He can be reached at Kelly.Robinson@ElectrostaticAnswers.com.

Is static electricity robbing you of productivity and eroding your profits?

Introducing the X-SERIES: Redefining Ultra-Performance in Static Elimination

NEW!

- Built around the most advanced technology yet, the X-SERIES provides exceptional performance, reliability, and smart technology to eliminate static electricity more effectively than ever.
- The built-in Adaptive Intelligence senses the static on the surface and automatically adjusts the ionization output of the bar as needed for highest performance.
- User interface displays the operating mode and level of charge detected in real-time.
- Industry leading, low-profile footprint for compact installations.
- Four models to match your application:

- **X-33:** extended-range applications, up to 60" plus, where highest power is needed—winding, large area coverage
- **X-20:** long range distance, up to 32", for a broad range of applications—web, conveyors, high profile parts
- **X-12L:** mid-range mounting, 4" to 24", static elimination for compact spaces
- **X-12F:** close range with rapid static elimination at the fastest machine speeds



NPE 2024 | May 6-10, 2024
The Florida West | Orlando, Florida
**SEE US AT BOOTH
W114**

TAKK Industries | 800-792-8255 | www.takk.com | sales@takk.com



TRP08

Sticking to Sustainability

The Advantages of Micropheric Adhesives with Ultra-removable Labels

By **Andrew Palmer**, Director of Sales, RRD Label Solutions

Adhesives are everywhere – on the sticky notes where we create to-do lists, the shipping labels that adhere to the packages delivered to our doorsteps and the critical, permanent labels on the appliances we use every day. While all adhesives serve different purposes, one labeling method of increasing importance is ultra-removable labels, which maintain their efficacy all while increasing companies’ flexibility, efficiency and progress toward sustainability goals.

While ultra-removable labels have existed in the industry for years, recent changes in customer preferences and organizational sustainability pressures have led manufacturers to increasingly

consider this type of adhesive as an alternative to the permanence of standard labels. Thankfully, due to their versatility, reusability and robustness, ultra-removable labels are a trusted technology for a variety of industries and applications – from lightweight adhesion on glass to applications on reusable plastic totes in distribution centers.

What are Ultra-Removable Labels?

Ultra-removable labels incorporate tiny bubbles within the adhesive label – that doesn’t allow them to fully stick to a surface, but makes them perform for the designed application in any conditions,

withstanding transit and extreme environments. Importantly, considering how high performing these labels are, they do not leave behind residue when removed. Whether attached to corrugated shipping boxes, plastic totes, glass or other materials, the labels are completely and cleanly removable.

Ultra-removable labels can enhance both a product as well as the overall customer experience by emphasizing a product’s basic attributes. For example, manufacturers across many industries require shipping labels to move their products from one point to another. But, what if they could utilize ultra-removable labels that allow customers to easily reuse shipping boxes or remove unnecessary branding labels from products once purchased? Ultra-removable labels can do just that, and manufacturers aiming to enhance overall customer experience can look to this adhesive for a simple, yet effective solution.

Sticking to Sustainability

According to a study¹ conducted by RRD, 94 percent of packaging decision makers across a variety of industries agree that sustainability is a key consideration in packaging and label decisions. While ultra-removable labels enhance the customer experience, they also support manufacturers in achieving their sustainability goals.

One of the main attributes of



ultra-removable labels is inherent to the name – they are able to be moved over and over again. Whether a label is accidentally affixed in the wrong place or is intended for multiple uses, being able to utilize ultra-removable labels cuts down on the need to create duplicate labels, which ultimately adds to a company's waste.

Beyond the initial implementation of ultra-removable labels, the addition of linerless label technology can heighten a company's sustainability efforts even further. Linerless labels omit the backing paper liner associated with many conventional labels, which can reduce a company's overall waste and even improve workplace safety by eliminating the slick silicone liners that can easily end up on

warehouse floors. The resulting combination of ultra-removable, linerless labels can take manufacturers from standard operations to sustainable methods through just a few simple decisions.

Ultra-removable Labels in Action

Demand for this technology is growing across various industries. Take the e-commerce industry, which constantly deals with customer product returns, especially in today's environment of consistent online shopping.

According to the National Retail Federation², for every \$1 billion in sales, the average retailer incurs \$165 million in merchandise returns. Many companies,

automatically, or upon request, include return shipping labels within the original shipment, in the event customers need to return items.

The return label can be removed from its paper backing, fastened to the original or new shipping box and returned to the manufacturer. At the next level, with the implementation of ultra-removable labels, manufacturers can fasten two labels to the original shipment – the return label on the bottom and the original shipping label on top of it. This means if the customer needs to return an item, they can simply peel off the top label, leaving only the return label ready for shipment. Not only does this again eliminate the paper backing associated with traditional labels, but it enhances

Opening Features

Straw Holes

Spouts

Ventilation Holes

Half Cut

Opening Perforation

Beverage Carriers/Trays

Liquid Packaging

Development and design of machines, modules and spare parts for the production of

Packaging

Inspection Windows

Level Indicator

Flexible Packaging

Tobacco Blanks

Holes

Braille Embossing

Embossing

Hot Foil

Hologram



Schobertechnologies GmbH
Industriestraße 2
71735 Eberdingen/Germany
Telefon +49 7042 790-0
info@schobertechnologies.de

Cutting and creasing with maximum efficiency and quality, thanks to Vector Technology



As a manufacturer of digitally printed folding boxes and in-mould labels, your best way into the future is with our new RSM520HD-DIGI-VARICUT. Thanks to our innovative drive technology, continuous and intermittent processes can be combined in the ongoing cutting and creasing process without changing the magnetic cylinder. For you, this means shorter set-up time, minimal tool costs and optimal workflow connection with reduced waste.

schobertechnologies.com when it comes to punching, stamping, cutting, perforating, creasing, scoring, embossing, sealing, ultrasonic welding, dispensing, applying, cut & place, collating, folding, gluing/bonding, or laser technology.

Please contact us! We can assist you – worldwide.



**No
Pain.
More
Gain.**



Isn't it time you took away the razor blades and used the original Ripper to open rolls? You'll reduce waste, improve roller life, and increase roll yield—and eliminate nasty accidents.

See the complete line and place your order at ripperonline.com. Or fax us at 1.317.298.1328.

**THE
RIPPER**

ripperonline.com • 1.800.783.7750

the overall customer experience with a truly seamless and efficient return process.

Another industry where we see the distinct benefits of ultra-removable labels is in the pharmaceutical industry. According to a controlled study³ of pharmacies, one in eight patients with a prepared prescription had at least one unclaimed prescription. While that may not seem drastic, that equates to tens of thousands of unclaimed prescriptions in just a few months.

When many pharmacies prepare prescriptions, they adhere labels with directions and dosage information directly to bottles or boxes. For the prescriptions that go unclaimed, that can equate to tens of thousands of bottles and boxes that go to waste due to the permanence of standard labels.

However, many pharmacies are seeing the direct benefits of ultra-removable labels, particularly when it comes to unclaimed prescriptions. By implementing these labels, pharmacists can remove the old label and fasten a new one for the next applicable patient, eliminating packaging waste due to labels that cannot be cleanly removed.

Small Choices Have a Major Impact

Ultra-removable labels enhance a product's purpose, improve the overall customer experience and aim to support companies' overall sustainability goals by reducing waste and increasing efficiency. Companies across various industries are constantly looking for big ways to enhance the customer experience and their sustainability efforts, but it is the small choices like switching to ultra-removable labels that can ultimately have a major impact. ■

1 <https://www.rrd.com/reality-report>

2 <https://nrf.com/media-center/press-releases/2022-retail-returns-rate-remains-flat-816-billion>

3 <https://pubmed.ncbi.nlm.nih.gov/28238663/>

ABOUT THE AUTHOR

Andrew Palmer is the director of sales for RRD Label Solutions. Developed in the early 1990s, CleanTac® is a market-leading ultra-removable adhesive trademarked by RRD, and remains the industry benchmark for microspheric label adhesives. To learn more, visit: rrd.com/services/packaging/labels.

35+ SPEAKERS

20+ PRESENTATIONS

180+ EXHIBITORS

**LEARN FROM THE TOP LEADERS IN
THE FLEXOGRAPHIC INDUSTRY!**



FORUM 2024

YOUR QUALITY IS OUR CONCERN

**EXPLORE THE LATEST DEVELOPMENTS
IN PACKAGE PRINTING TECHNOLOGY!**

INF  **FLEX**
2024

KANSAS CITY, MO | MAY 5-8

LOEWS KANSAS CITY HOTEL & KANSAS CITY CONVENTION CENTER



**LEARN MORE AND REGISTER AT
FORUM.FLEXOGRAPHY.ORG**



SCAN HERE



Photo courtesy of INX International Ink Co.

New INXCure™ CardPro UV Offset Inks Introduced

INX International Ink Co. recently announced the introduction of INXCure™ CardPro, an offset plastic lamination ink system designed for the plastic card market. It delivers stronger, longer-lasting performance with the highest lamination bond strength available to brand owners and printers, and addresses the need of an advanced solution for a growing marketplace.

Tosaf Develops PFAS-free Additives for Plastics Industry

Tosaf, a globally active manufacturer of additives, compounds and color masterbatches for the plastics industry, has developed processing aids for the extrusion of polyolefins that do not contain fluoro-



Photo courtesy of © PlasticTime

elastomers. They can be used without restriction in place of conventional products currently affected by the PFAS debate, are suitable for a wide range of film applications, and they meet the requirements of the FDA and EFSA for use in contact with food. While AP9709PE EU provides enhanced rheological properties, AP9711PE EU is the grade of choice if the focus is on optical properties, including clarity and haze.

INDUSTRY NEWS



Photo courtesy of Dixie Signs & Decals, Rollem International

Dixie Signs & Decals, Inc. Upgrades Technology with Rollem

With the desire to update its kiss-cutting methods, Dixie Signs & Decals, Inc. recently met with Rollem International at the Printing United trade show for a demonstration on its 36-inch Semi-Slitter Model. Impressed with the speed and depth of cut accuracy, the width proved ideal for its largest products requiring back slitting. “Since the day it was installed, we’ve been very pleased with the ease of operation and dependability of our Rollem Semi-Slitter,” stated Richard Milberger, Dixie Signs & Decals, Inc. president.

CNG Builds Portfolio of Store Drop-off Ready Films

Charter Next Generation (CNG), an innovator in sustainable films, has received its 250th How2Recycle® Store Drop-off pre-qualification letter. CNG’s portfolio of pre-qualified films, which ranges from off-the-shelf varieties to custom blends, makes it easy for companies to make environmentally responsible choices while pursuing Store Drop-off qualification on their own. How2Recycle is a standardized labeling system that clearly communicates disposal instructions to the public. It is driven by a coalition of brands that want consumers to be empowered through smart labeling systems. Pre-qualification allows material manufacturers and converters to vet their products in advance to qualify to use the How2Recycle Store Drop-off label. ■

Baldwin Technology: A Leader in UV Curing Systems for Converters

Baldwin Technology, part of the BW Converting Solutions platform, is a global leader in the design, manufacturing and service of conventional UV, LED-UV, and IR systems meant for industrial use.

LED-UV

Baldwin's AMS Spectral UV XP Series, engineered to retrofit LED-UV systems onto existing printing presses, significantly lowers energy consumption, decreases downtime, and extends the lifetime of the press versus conventional UV systems.

The XP Quatro features the proven LED-UV technology developed for printing presses, with a design adapted for the converting industry. It uses the same optics and LED chips as the standard XP product line, but doubles the UV energy by placing two independent rows within one housing while only increasing the size by 1" (25mm) in machine direction. This results in a higher total UV energy exposure (dose, J/cm²) in a compact footprint. The XP Quatro design also provides an economical solution for applications with two LED-UV wavelengths on the same production line.

Arc Lamp Systems

The use of conventional UV technology (medium pressure mercury lamps) has been used by the converting industry for over 50 years. Baldwin's QuadCure arc system utilized CFD software to minimize air impingement on reflectors and target the cooling air only for the bulb. The system utilizes water cooling in the shutters and



housing, minimizing the external housing temperature and heat transfer to the conveyor and tooling, and increases bulb life by focusing the air-cooling on the bulb.

Another unique innovation is the Cool Arc product line. This design is modular with high power capability up to 600 W/in (240 W/cm), built-in air cooling, fast acting dichroic shutters, integrated quartz plate, and toolless lamp replacement. This is ideal for laboratory/pilot lines and applications of 85mm to 400mm.

Service and Support

Baldwin manufactures bulbs for QuadCure, Cool Arc and other OEM systems at its manufacturing facilities in Easton, Pennsylvania and Slough UK. Services

including installation, start-up, training and maintenance are performed by a global team of highly trained service technicians. Multiple locations around the world have spare parts in stock to keep customers' lines up and running.

BALDWIN®

For more information, please contact:
 Craig Black, Vice President of Sales,
 Americas: craig.black@baldwintech.com
 Kevin Joesel, Industrial Sales Executive,
 Americas: kevin.joesel@amsspectraluv.com

Or visit www.baldwintech.com

Dover Flexo Electronics – Celebrating 50 Years of Tension Control Innovation

Dover Flexo Electronics (DFE), a recognized innovator in tension control technology, is celebrating its 50th year manufacturing load cells, amplifiers, display indicators, closed-loop controllers, pneumatic brakes and idler rolls. DFE tension systems deliver improvements in material processing productivity and reliability, helping to reduce waste and operating costs. Industries such as flexible packaging, paper, film, foil and web converting are their specialty.

Investment in a new tension measurement system often begins with the installation of a *Tension Roll®* transducer or cantilevered *Narrow Web* transducer. The *Tension Roll®* and *Narrow Web* both combine a roll shell with dual tension sensors in a robust, shaft-centric design. The roller systems are ordered to spec and require no assembly — just bolt them onto the machine. *Tension Roll®* and *Narrow Web* transducers are available in a wide range of diameters and lengths with load ratings from 12 to 400 lbs (53 – 1779 N). CAD models in 60+ native formats are available for download on each product page ensuring design integration is quick and easy.

DFE also manufactures *Model C* cartridge-style tension transducers, considered to be the industry standard in high-sensitivity semiconductor strain-gage load cells. These workhorse tension sensors are available to support live-shaft and dead-shaft idler rolls with a wide variety of mounting styles and load ratings that range from 10 to 800 lbs.

The semiconductor strain-gage technology featured in all DFE load cells delivers up to 33x more signal performance than some foil gage alternatives. In combination with the refined digital signal processing techniques used in their amplifiers, indicators and controllers — DFE's tension systems are capable of delivering an incredibly wide range of sensing performance for a given load rating. This technology advantage provides added flexibility for customers who may need to repurpose their load cells for new applications or



evolving job requirements.

DFE's *TrueView™* 1100 series touchscreen tension display indicator features an easy-to-use HMI menu and integral trend graph. Other features include a bright 500 nit, impact-resistant display and a compact, aluminum enclosure machined from solid 6061-T6 alloy for excellent durability and heat dissipation.

In 2021, DFE launched the *TA500-EIP* tension amplifier featuring simultaneous EtherNet/IP™, 0-10 VDC and 4-20 mA connectivity for compatibility with current and next-generation PLC systems. In 2023, DFE announced the addition of EtherCAT® protocol support with the launch of the new *TA500-ECAT* tension amplifier.

For turn-key control retrofits, the *SteadyWeb 6™* digital tension controller delivers precise closed-loop performance with an incredible amount of flexibility and adjustment. *SteadyWeb 6™* was designed with modularity in mind, providing torque control options for electric and pneumatic brakes, clutches and motor drive systems. The intuitive touchscreen interface greatly

reduces the time and effort needed to train operators.

DFE's full line of pneumatic tension brakes are both simple to operate and reliable. The time-tested design features stress-relieved iron discs, tool-less quick-change pads and limited-travel pistons. Each brake is assembled and balanced in a methodical process that minimizes runout for ultra-smooth torque engagement. Patented *Silence™* friction pads are extremely effective at eliminating brake squeal — providing environmental and safety benefits for operators who work in close proximity to braking systems.

All DFE products are manufactured in the USA and backed by an industry-leading 5 year tension-free warranty.



Phone: (603)332-6150

Website: www.dfe.com



TENSION MEASUREMENT & CONTROL SYSTEMS

A Legacy Of Tension Control Innovation & Performance

DFE is a leading provider of tension measurement and control systems with over 50 years experience serving a wide variety of industries and applications. Our load cells utilize highly-sensitive semiconductor strain gages that deliver category-leading performance and durability. DFE amplifiers and controllers deliver impressively high resolution with little to no drift. For these reasons and more, we confidently stand behind all of our products with an industry-leading 5 year warranty.

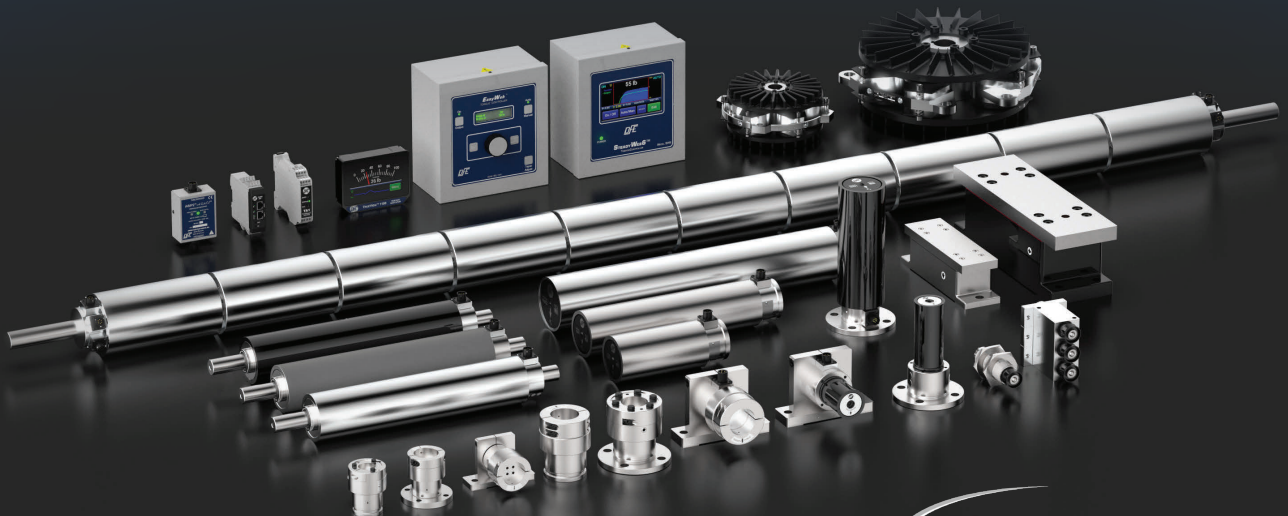

APRIL 18, 2024

Green Bay, WI - **BOOTH 306**

A Vision For The Future

Connected devices for smart factories are rapidly transforming control system architectures, enabling better integration of plant resources, equipment and information. DFE load cells and amplifiers with EtherNet/IP™ and EtherCAT® connectivity are a perfect fit for machinery with next-generation requirements such as remote monitoring and diagnostics.

We're eager to share our experience designing systems and components that can achieve your performance objectives. We hope you'll join us at Converters Expo 2024 to discuss your latest projects and application requirements - see you soon!



ETI: Pioneering Innovation in Label Manufacturing

For over two decades, ETI Converting has dedicated itself to providing label printers and converters with an unparalleled level of technology, innovation, and freedom in label creation. As pioneers in the art of in-house coating, **we design and build specialized equipment for inline label printing, coating, and converting.** Our results-driven approach has been proven in over 40 countries worldwide and is geared towards enhancing your profitability, expanding your product portfolio, adapting to high-volume production, and eliminating external sourcing of pressure-sensitive labelstock.

Transformative Innovations Redefining Business Dynamics

ETI has created a revolutionary alternative that has led to a seismic shift in the value chain. In essence, we've developed the equipment and resources to produce the pressure-sensitive labelstock yourself, using your choice of raw materials including paper or filmic substrate, silicone, and adhesive.

This transformative approach isn't just about manufacturing your own material, it's about changing the way label printers like you do business. Whether you're manufacturing VIP, Prime, Promotional or Functional labels, our innovative solutions will move your business forward. Embrace this new era and experience the independence to create all kinds of labels seamlessly from start to finish, unlocking unparalleled freedom in label creation.

Narrow- and Mid-Web Coating and Converting Excellence

Striking innovation, unrivaled autonomy, and patented technology are just a few of the advantages strategically built into all of our equipment. Whether it's Cohesio,



LinerO, Acuro or our custom solutions, you can rest easy knowing that each machine is manufactured to the highest standards and designed to keep you competitive in the long run.

- **Cohesio**
ETI's premium narrow-web printing, coating and converting machine for inline label manufacturing.
- **LinerO**
Linerless label manufacturing equipment to produce sustainable VIP and prime labels of all kinds.
- **Acuro**
Flexible web coating and laminating machine for pressure sensitive labelstock and tape manufacturing.
- **Custom solutions**
Custom web coating equipment to create and manufacture made-to-measure labeling products.

We put all options on the table

We provide a comprehensive range of options to meet your specific needs:

- **Range of widths:** from 13 in up to 64.5 in (other widths upon request)
- **Printing:** flexography, gravure
- **Silicone coating:** UV-curable silicone
- **Adhesive coating:** rubber-based hotmelt, UV-curable acrylic hotmelt, acrylic water-based
- **Converting:** slitting, sheeting, die cutting/perforation

Innovation as a Commitment

At ETI, innovation is not just a goal; it's our unwavering commitment. Our approach goes beyond the ordinary, with multidisciplinary teams dedicated to understanding the unique preferences and requirements of each client. From conceptualization to configuration, we empower our clients with the knowledge needed to make informed decisions about raw materials and production recipes. This personalized, result-driven approach ensures that every collaboration with ETI is a journey towards maximum return on investment.

ETI Expands its Global Reach

In 2023, ETI announced the opening of its first subsidiary in Spain. The new European subsidiary will function as a hub for sales, programming, and service technicians, complementing the existing sales force currently operating across the continent.



ETI Converting Equipment
450-641-7900
sales@eticonverting.com
eticonverting.com



Tap into the potential of linerless labels

Create all kinds of labels with ETI's inline printing, coating and converting equipment.

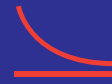

Linerless labels:

- Wraparound
- Direct thermal
- Specialty labels with partial adhesive
- Tape
- And more



eticonverting.com
sales@eticonverting.com

A leader in bag converting equipment

Hudson-Sharp, part of BW Converting Solutions, is a global leader in the design, manufacture, and service of plastic bag-making equipment, pouch-making equipment, and recloseable solutions for the bag-converting industry worldwide. With more than 100 years of experience, Hudson-Sharp sets the standard for high-performance equipment, including wicketers and stand-up pouch machines, as well as industry-leading technology and innovation as demonstrated by our revolutionary INNO-LOK® and POUR & LOK™ pre-applied closure products. Our innovative team of engineers can custom design machinery for all your flexible packaging applications and our dedicated support staff is here to provide world-renowned customer service.

ARES 400-SUP

Hudson-Sharp has been leading the way on polybag machines and polyethylene (PE) pouches for years and continues to do so with our innovative Ares 400-SUP pouch machine. It was created from listening to our clients' changing needs and is the perfect complement to label and narrow web printers. The Ares 400-SUP stand up pouch machine is a compact, efficient, easy-to-operate, quick-changeover machine designed for short to medium production runs. And to help customers meet sustainability goals and mandates, it runs recycle-ready PE, paper, and biofilms, in addition to laminated films, with ease and a low scrap rate.

INNO-LOK®/EZ-STAND/ POUR & LOK™

Innovative flexible packaging solutions are a hallmark of Hudson-Sharp's legacy as demonstrated by our INNO-LOK®, EZ-STAND and POUR & LOK™ contributions. Our INNO-LOK machine provides the flexibility to run either recloseable or regular bags on any packaging lines without additional capital expenditures. Our EZ-STAND innovation is a pre-applied bottom gusset on a roll that can easily produce



stand-up pouches on a VFFS machine. The EZ-STAND pouch is made by utilizing an INNO-LOK machine along with a universal applicator which allows VFFS pillow packs to stand up with the same efficiency and economy. And our highly innovative POUR & LOK feature produces resealable side-gusseted bags and pouches ideal for pet food, lawn and garden, and snack applications. Utilizing roll stock with pre-applied closures creates value by providing higher production rates, no reduction in processing speeds, less scrap, and less down time.

INDUSTRY 4.0

Through options like video troubleshooting and data monitoring, our Accelerate™ services minimize down time for our customers around the world. We can offer maintenance alerts, quicker response times, and immediate recommendations that can prevent costly equipment failures.

SERVICE & SUPPORT

We know you rely on our machines to keep your business moving forward and we stand behind our equipment. We offer a variety of services including installation, start-up, training, and maintenance performed by a global team of highly trained service technicians. We also have multiple spare parts stocking locations around the world to keep your business up and running.



Piergiorgio Assandri

Product Manager - Bag Converting
piergiorgio.assandri@pcmc.com

Hudson-Sharp

2300 South Ashland Avenue
 Green Bay, WI 54307-9005
 +1 (920) 491 6050
 Mobile +1 (920) 461-7279



Stand-up pouch machines

Built for efficiency and ease of use

Big performance in a small footprint

200 CPM, compact size, quick changeovers, and low scrap



Variety of substrates

Laminated films, paper, recycle-ready PE, compostable and biodegradable films

Ideal for the food and grocery, personal care, hygiene, cannabis, and non-food, bulk packaging industries.

HUDSON-SHARP | The logo for Barry Wehmiller Better World, featuring the letters 'b' and 'w' in a stylized font with 'betterworld' written below.

hudsonsharp.com | bwconvertingsolutions.com

LAEM IMS – Slitting and rewinding solutions always keeping pace with the evolving needs of the converting industry

LAEM IMS is a **manufacturer of slitter rewinders** established in 1972 that has grown significantly to become a key player in the design and manufacturing of equipment used in the converting industry. Since 2020, LAEM has been a part of the IMS TECHNOLOGIES Group, enriching the company's portfolio with extensive expertise in the flexible packaging sector.

The product portfolio of LAEM IMS includes **twin-shaft, turret, and compact slitter rewinders**, along with technologically advanced end-of-line full automation systems essential for processing various flexible packaging materials as well as paper, film, laminates, aluminum, and coated materials. The brand excels also in fully integrated automated solutions, positioning itself as a pioneer in automation and robotics.

LAEM IMS dual shaft and turret solutions for the flexible packaging industry

Dual Shaft slitter rewinders

LAEM IMS's dual shaft solutions are meticulously designed to rewind and produce high-quality finished reels with large diameters. The benefits of choosing a dual shaft machine include increased productivity, perfect tension control, cost reduction, high production quality, great flexibility, and high reliability.

Turret Solutions

The turret slitter rewinders from LAEM IMS are engineered to achieve high production speeds. Coupled with the automatic change-over feature, these solutions drastically reduce machine downtimes, with the ability to restart in less than one minute. The advantages of choosing turret slitter rewinders include: no machine downtimes, increased productivity, a seamless production cycle, high-quality finished reels, and a center-driven configuration.

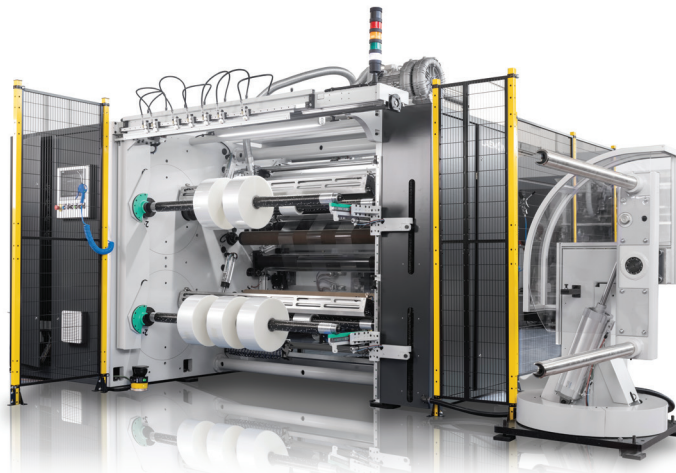

Highlighted Series in the Portfolio

Within our portfolio, two series stand out: the RIBOSLIT series and the RB series.

RIBOSLIT SERIES: a unique design, synthesis of quality, performance and safety

The RIBOSLIT Series caters to film manufacturers and converters seeking to combine reduced operational space and investment with top-notch components. This series includes the compact dual shaft slitter rewriter, RIBOSLIT 2, and the compact double turret slitter rewriter, RIBOSLIT 4. Boasting an innovative and ergonomic design, along with a revamped operator-friendly software and HMI, the RIBOSLIT Series can rapidly process a wide range of films and laminates within the flexible packaging industry.

Both RIBOSLIT 2 and RIBOSLIT 4 share identical features, ensuring a minimal footprint and high efficiency. However, their configurations differ, providing the RIBOSLIT Series as a versatile solution tailored to meet each customer's unique production requirements.

RB SERIES: Converting has never been so easy

The RB 2 slitter-rewinders, with their exten-

sive array of accessories and highly flexible configurations, are carefully crafted to fulfill the production requirements of the converting industry. Leveraging **center-driven winding technology** and state-of-the-art differential shafts, these machines enable the production of very narrow reels while maintaining consistent tension and hardness across the entire width.

Designed specifically for film manufacturers and converters aiming to produce multiple finished reels with relatively small diameters, the RB 4 offers a significant reduction in cycle downtime compared to a dual shaft machine. This is achieved by minimizing change-over time and establishing an efficient production rhythm for operators. The standard configuration includes two rewinding motors for independent control of the upper and lower shafts.

In summary, LAEM IMS, through its **commitment to innovation** and a diverse product range, plays a crucial role in advancing the capabilities of the flexible packaging industry. The brand's offerings prioritize efficiency, reliability, and cutting-edge technology, meeting the evolving needs of manufacturers and converters on a global scale.



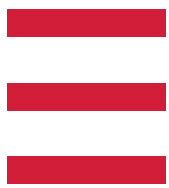

LAEM O IMS

A BRAND OF IMSTECHNOLOGIES

REVOLUTIONARY Slitting and Winding Solutions for the Flexible Packaging Industry

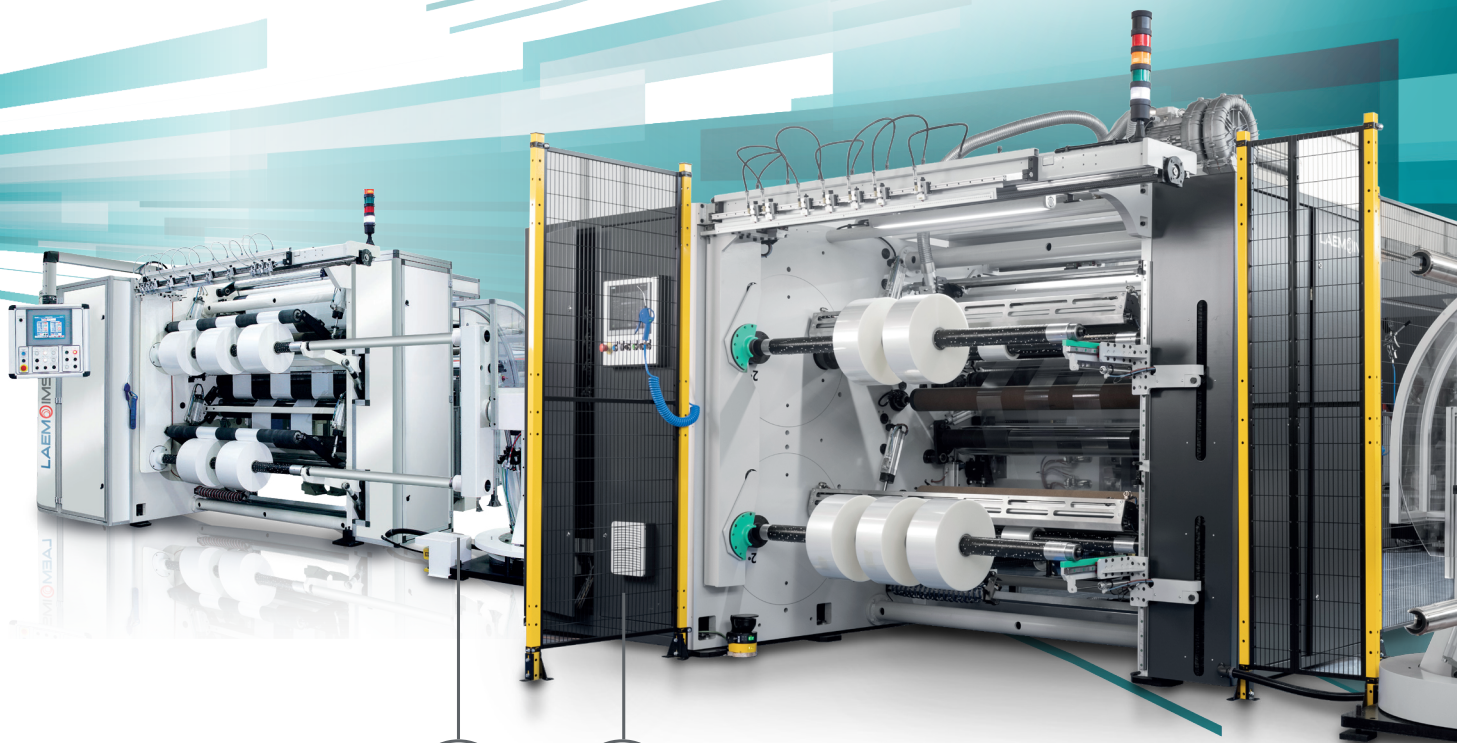

RB
SERIES

Dual-shaft turret
slitter rewinders
for quick cycle times

RIBOSLIT
SERIES

Compact high technology
slitter rewinders
for the flexible packaging industry



www.laem-ims.com

sales@imstechnologies.com



Seamless Quality Monitoring from Raw Material to Finished Roll

ISRA VISION is a leading global supplier of automated, camera-based industrial image processing technologies. The company's advanced inline optical inspection solutions have been used for over 35 years in a vast range of industries, including battery, plastic film, printing, and packaging where they make a key contribution to quality control and sustainability by promoting the conservation of finite resources and the continuous optimization of process chains.

SMASH – Inline Inspection Solutions for Plastic Films

ISRA VISION's SMASH systems offer custom, application-specific solutions for the inline inspection of plastic films including blown, cast, and biaxially oriented (stretch) grades. These solutions are well suited for transparent, matt, and opaque films as well as metalized surfaces. Thanks to their combination of powerful hardware and comprehensive software tools, ISRA VISION's inspection solutions enable 100% quality monitoring from the extruder to the finished wound and converted roll, maximizing reliability right along the value chain.

Applications range from the manufacture of films for flexible packaging, food, and pharmaceutical packaging, battery web products, release liners, and interlayers for laminated glass to optical films like prismatic or polarizer films.

The latest, high-resolution embedded and slim camera systems combined with ultra-bright smart LED lighting modules are the powerful hardware platform for ISRA VISION's inspection solutions. Due to In-house development and manufacture these components can be optimally tailored to the customer's requirements for the specific application, e.g., to different web widths and web speeds. Additionally, both light and dark field inspection are possible, so enabling reliable detection of typical defects such as holes, gels, fish eyes, streaking, soiling, oil spots or insects, etc.

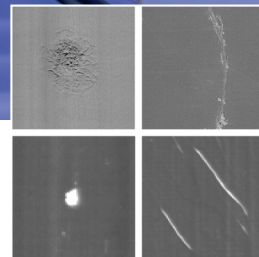
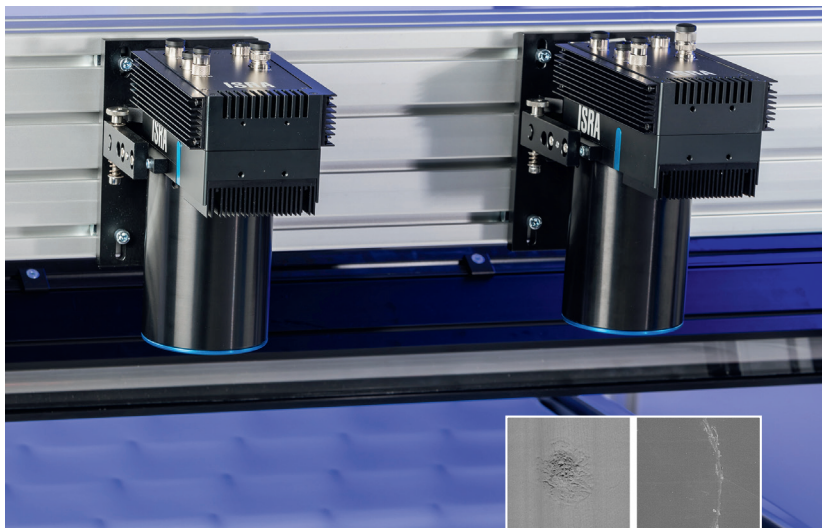

Comprehensive User-friendly Software Suite

In addition to innovative hardware technologies, ISRA offers comprehensive software platforms as a centralized or browser-based Touch&Inspect architecture with an intuitive and customizable user interface. Proven classification tools like QuickTeach are being joined by new self-learning AI-based classifiers. These automatically segment and classify defects and surface properties but also achieve the best possible result thanks to new deep learning methods. Subsequent manual retraining of the system to boost defect detection and differentiation is straightforward. This boosts yield because optimized classification leads to disregarding defects that are insignificant for a particular application. Only relevant defects must be documented and subsequently sorted out.

In addition, ISRA's Beyond Inspection software solutions such as RewindManager and SlitOptimization provide valuable assistance with conversion. For instance, RewindManager makes it easy to eliminate possible errors during conversion of the finished rolls by automatically stopping the slitter or doctor machine at the exact position of the defect. Comprehensive reporting functions round out the suite, enabling

complete documentation of the production process and quality for the customer.

These software solutions contribute to increasing quality, yield, and output, reducing customer complaints, lowering material and energy consumption, and ensuring greater sustainability in the production of plastic films.

The company also supplies the SurfaceSTAR SIS surface inspection system and SurfaceSTAR GS gel sensor system to blown and cast film manufacturers for coating and converting systems. These pre-configured standard modules can be integrated directly into the products ex-works, while their plug-and-play functionality means they can be easily adapted to existing production environments.

Get in touch with our experts

**ISRA
VISION**
Part of Atlas Copco Group



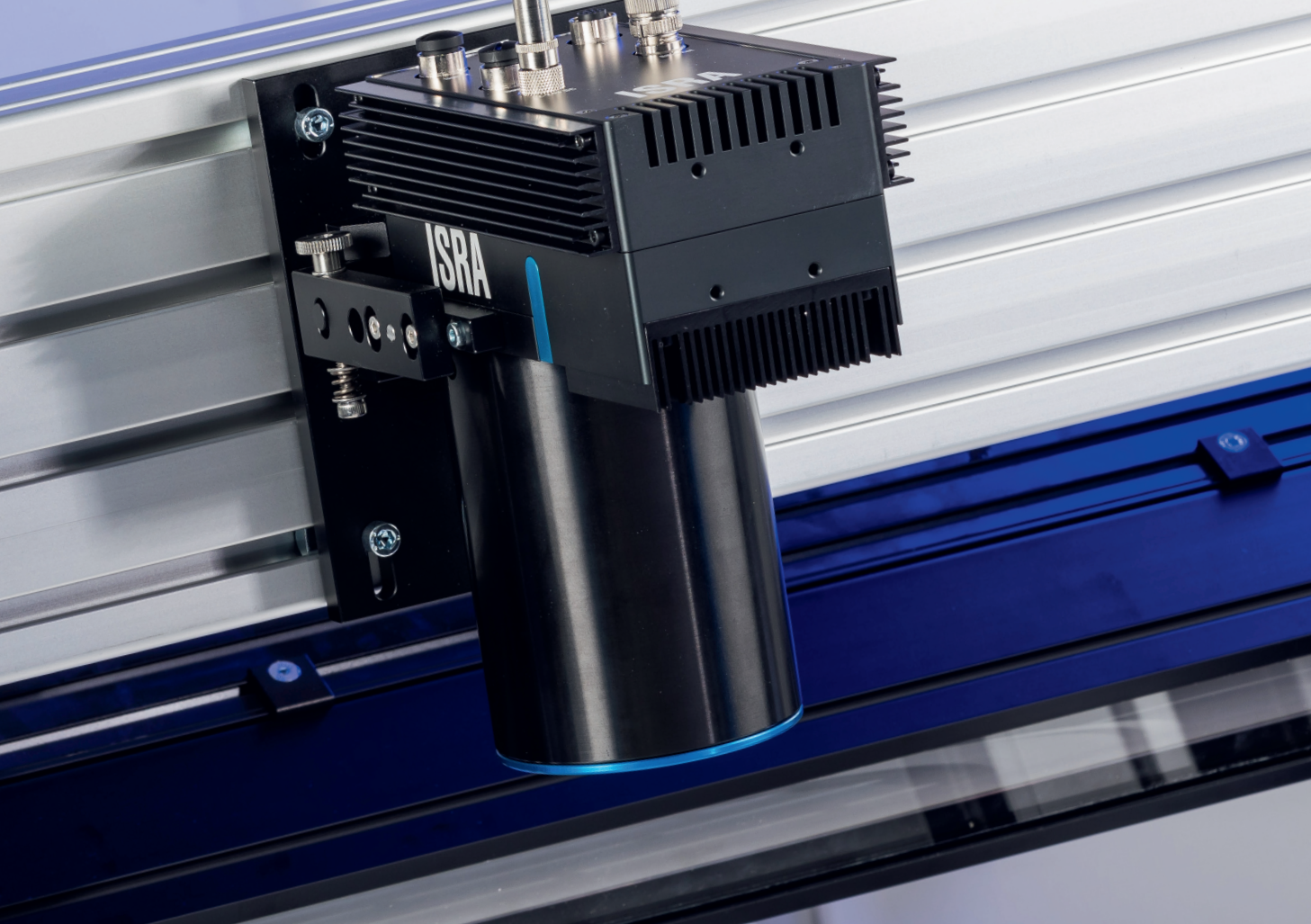

Get in touch
with our experts



EMPOWERING VISION EXCELLENCE

for plastic film inspection



Enhanced automated inline inspection
for plastic film



Automated defect classification



Reduce scrap and energy
consumption by up to 10 %

www.isravision.com

ISRA
VISION
Part of Atlas Copco Group

A leader in printing equipment

Paper Converting Machine Company (PCMC), part of BW Converting Solutions, specializes in the design, manufacture, and service of high-performance converting machinery for the printing, tissue, and hygiene industries worldwide. Our comprehensive print industry products include a complete range of central impression, in-line, and offset printing presses; digital hybrids and conversions; and award-winning laser anilox cleaners for the flexible-packaging, prime-label, and carton-converting industries.

LASER ANILOX CLEANER

The Meridian Elite's patented laser technology deep cleans engravings of any line screen without increased surface temperature or hot spots. The deep cleaning allows the anilox to perform at correct volumes – saving time, ink, and waste. The fastest cleaning cycles in the industry along with smart and connected features keep your shop operating at peak efficiency. Winner of the 2020 FTA Technical Innovation Award and 2020 Label Industry Global Award.

FUSION C

The Fusion C central impression presses were developed to meet the demands of short length runs that require more efficient changeovers and setups with high repeatability and maximum uptime. Features such as TruePrint, a camera-based impression and registration system, and SteadyPrint anti-bounce technology further enhance the Fusion C's ability to produce high-quality output through a wide speed range.

DIGITAL

Our ION digital conversion system and hybrid press options offer flexible inkjet printing for many platforms including labels, folding cartons, wide web packaging and other specialty printing markets. The industry leading 1600x1585 dpi native resolution is one of the highest in the industry and can print in different print modes pushing print speeds up to 668 ft/min. Powered by Memjet's



drop-on-demand thermal inkjet technology, each print head fires more than 3 billion dots per second. The new aqueous pigmented ink set offers a durable, lightfast solution to your digital print needs, and can be configured from 8.5-inch print width up to 60 inches. ION digital print technology is available as a mono-color print bar and full color printing platform with expanded gamut printing.

ELS-MAX

The ELS-MAX has taken inline printing to a new level. It is the first inline press to incorporate the features and advantages of both CI and inline presses. The register tolerance is the best in the inline industry and matches what CI presses can hold. Our True Print Plus option auto sets registration and impressions from a PDF file - saving time, material and ink. Operators simply press one button to start the make-ready process. The ELS-MAX can be customized

with additional features such as inline lamination, UV curing, backside printing without a turn bar, rail system and more. The print stations are fully servo-driven with direct drive, eliminating all gears and most common wear parts. A variety of unwinds and rewinds are available for all applications from short run to continuous run. The ELS-MAX can run a wide range of material types and thicknesses ranging from thin films to board stock.



Rodney Pennings

Director of Sales
 rodney.pennings@pcmc.com
 Paper Converting Machine Company
 2300 South Ashland Avenue
 P.O. Box 19005
 Green Bay, WI 54307-9005
 +1 (920) 491-6674 | m +1 (920) 362-4931

They're not machines, they're solutions.

Where
technology,
reliability and
performance meet

The FUSION series of
central impression printing presses



Where fastest,
smartest and safest
come together

The MERIDIAN Elite
laser anilox cleaner

Equipment designed to help solve problems

Let us help you maximize efficiency, reduce waste, deliver quality,
increase productivity, and ease the strain of labor shortages.

INLINE, CI, DIGITAL & OFFSET PRESSES | LASER ANILOX CLEANERS



pcmc.com | bwconvertingsolutions.com

QC Electronics: Unrivaled Corona Treatment Solutions

QC Electronics specializes in the manufacture of robust, quality corona treaters that deliver above-average results. We are known for pushing the boundaries of corona treatment since our inception in 1988. QC's team is driven by a passion for the craft and a commitment to top-notch quality.

About our people

As a family-owned and operated company specializing in the manufacture of cutting-edge corona treatment systems, our close-knit group embodies a unique blend of camaraderie and expertise. QC fosters an environment where questions are embraced, and authenticity prevails. The company has cultivated an approachable, collaborative, passionate team capable of delivering proven solutions in every project undertaken.

About our equipment Proprietary Technology + Unique Design

Every facet of our operations is designed to ensure longevity and dependability in our equipment. Renowned for a robust and powerful build, QC corona treaters have become synonymous with longevity. We take pride in being the exclusive manufacturer of corona treaters featuring our proprietary technology and design. Operating on unique technology and crafted with premium techniques and materials, the quality of the equipment is undeniable. Our adherence to premium construction paired with cutting-edge technology emphasizes our commitment to establishing corona treatment as an enduring and dependable process.

Smart Corona - Better Results

QC's corona treaters combine reliability with intelligent features. Each unit boasts autonomous power control and advanced options such as electronic air gap adjustment. We uniquely generate the corona field, safe-



guarding materials from electric field-related damage—an innovation exclusive to QC. Our technology allows us to treat a wider range of materials than typical corona treaters, opening new doors for both QC Electronics and our customers. We remain the sole manufacturer presenting corona discharge in this distinctive manner.

New in 2024: Double Corona Treater Demo Line

QC Electronics is set to unveil a cutting-edge lab line April of 2024. The line will include an Advantage bare roll corona treater and a TNT Touch N' Treat covered roll corona treater capable of treating webs up to 60" wide with single or double-sided treatment. Equipped with tension control and advanced features, this production line replicates those found in customer facilities. This addition allows for efficient processing of short job runs, enabling customers to explore both new and existing processes.

Product Catalogue Corona Treaters

- **Advantage Narrow Web Corona Treater**
Our compact yet highly reliable narrow web corona treater defies the norm. A unique design that ensures reliability doesn't shrink with size.

- **Mid-Wide Web Corona Treaters**
QC Electronics stands out prominently in mid-wide web corona treaters. Our Advantage and TNT models offer unparalleled durability, establishing themselves as the workhorses of their class.
- **Sheet Corona Treaters**
- **Lab Corona Treaters**
- **Plasma Treaters**
- **Custom Corona Treaters**
- **Corona Treater Generators up to 40.0-Kilowatt**

Parts and Services

- Ceramic Electrodes
- Rolls, Coatings and Recovery
- Waterjet Cutting
- Lab Testing
- Consulting
- Custom Solutions

Visit our website at www.qcelectronics.com for a full product offering.



Contact Us

Alyxandria Klein
Marketing and Sales Director
Email: sales@qcelectronics.com
Phone: +1 608 742 1661
Website: www.qcelectronics.com

Smart treaters.

When it comes to reliability,
we don't just set the bar –
we are the bar.

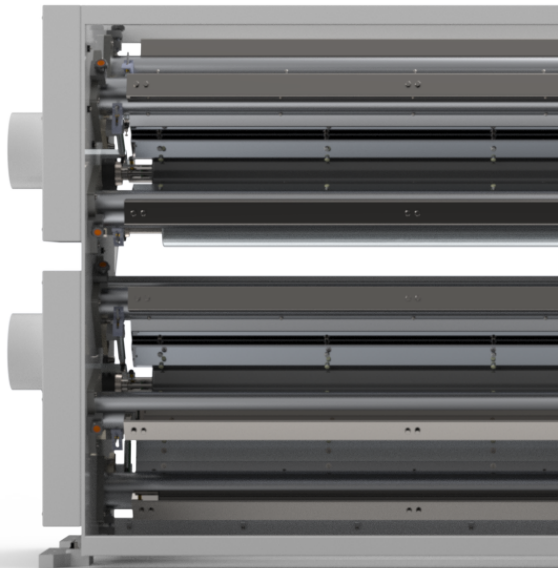

Better results.

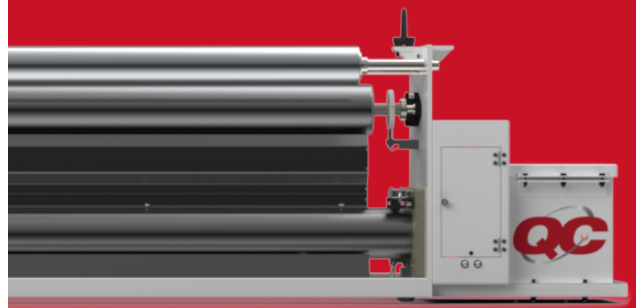

- recipe programming
- watt density control
- operator lockout
- field bus friendly



Leader in Advanced Sensing and Control Solutions

Roll-2-Roll Technologies has revolutionized the roll-to-roll industry with its advanced sensing and control solutions. Our team of experts, who are well-versed in various web handling aspects, including lateral dynamics, longitudinal dynamics, winding, rewinding, and print registration control, bring a unique blend of academic and industry expertise to the table. Our mission is to make technology more accessible by providing simple solutions that make our customers' lives easier.

Our flagship product, the Roll-2-Roll® Sensor, exemplifies this philosophy. This plug-and-play solution can detect any material without the need for setup or calibration, making it one of the most efficient and user-friendly sensors on the market. Its accuracy and high resolution of 0.0025" and sensor range up to 960 mm or 37.8" make it ideal for multiple applications, such as web guiding, edge sensing, web width measurement, thread counting, flag detection, splice detection, registration mark detection, fold detection, defect detection, and missing end detection.

Our products are based on strong fundamental research funded by the National Science Foundation (NSF) and Oklahoma Center for the Advancement of Science and Technology (OCAST). They are constantly being improved based on customer feedback.

At Roll-2-Roll Technologies, we believe that "Simplicity is the ultimate form of sophistication." Our products reflect this philosophy. We are dedicated to listening to our customers and proactively working to reduce the unnecessary complexities of technology. We invest countless hours on R&D to save our customers precious minutes. Our multi-purpose line of sensors and controllers offer multiple applications



that are easy to install and operate. Our goal is to simplify the web handling process and reduce inventory and part numbers, improving your operation.

Our expertise is in web guiding, web width measurement, web position measurement, and defect detection. We serve a diverse group of customers in the paper, film, foil, packaging, textile, metals, food, tire/rubber, medical, battery, and specialty converting industries.

We are committed to providing our customers with cutting-edge, reliable, and effortless solutions that improve their operations and meet their needs.

At Roll-2-Roll Technologies, we value reliable and efficient customer service. Our team is responsive and available to answer your questions promptly. We have a wealth of documentation on our website, and our

experts are on-site in the USA to provide support. We also offer video and remote support for global customers. We take pride in providing the highest level of service to ensure that our customers are satisfied with their purchase and have the support they need to achieve their goals. You can trust that your needs will be met with the utmost care and attention at Roll-2-Roll Technologies.



1110 S Innovation Way
Stillwater OK 74074
W: <https://r2r.tech>
P: +1-888-290-3215
E: sales@r2r.tech

Streamline your operations with the **Roll-2-Roll**® Sensor

One Sensor, Infinite Possibilities

Web Guiding

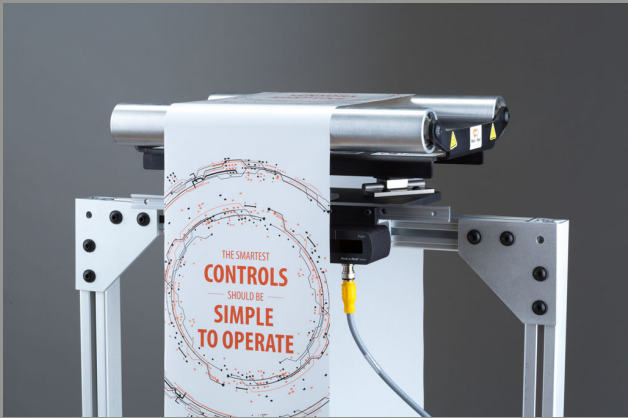

Web Width Measurement

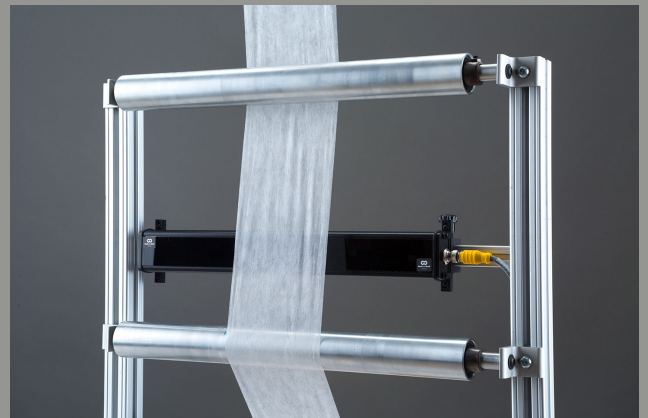

Elastic/Thread Counting

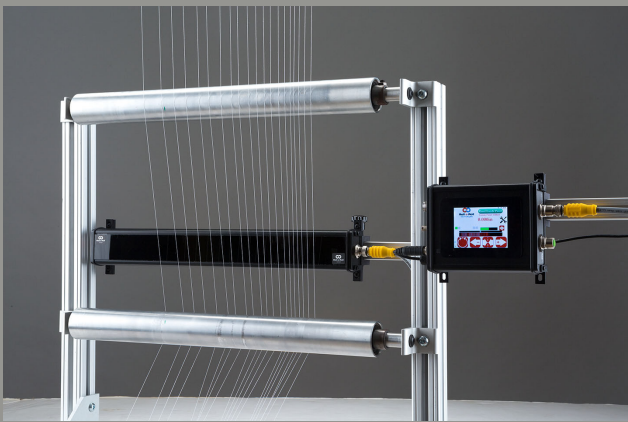

Multiple Strip Width Measurement

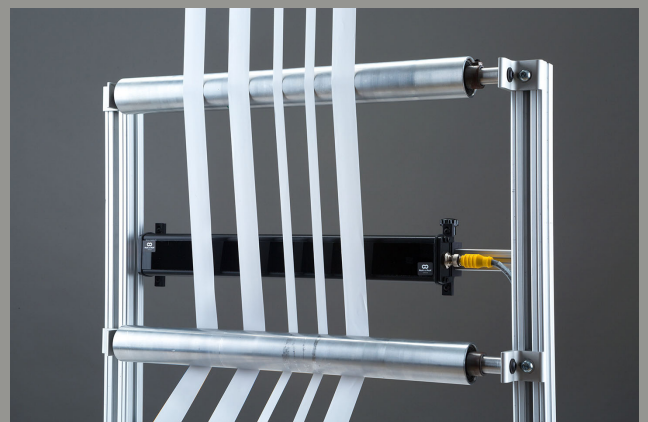

One Sensor, Infinite Possibilities

Don't let the complexities of technology hold you back, upgrade to the **Roll-2-Roll**® Sensor to simplify your operations. With its compact one-sided design, it's easy to install in tight spaces and can be used for a variety of applications including *web guiding, edge sensing, web width measurement, elastic/thread counting, flag detection, splice detection, registration mark detection, fold detection, defect detection, missing end detection* and more.

Don't waste time and money on multiple sensors for different applications. Trust the **Roll-2-Roll**® Sensor for all your needs.



Leaders in Converting Industry — Precision, Narrow Width Slitting & Rewinding Services

Ours has always been a service-based, niche industry. With 77 years of experience, Metlon Corporation has built its business across every industry, and by working within every department – from research and development and engineering to sales, production, and shipping. Our leadership position is based on capabilities and service.

Capabilities means Metlon is able to hold precision tolerances down to + 0.001" (or 0.025mm) and specializes in narrow width slitting, as narrow as 0.008" (or 0.2mm). For our customers that means meeting specifications in R&D projects and long production runs – some projects are short-lived, others continue for years.

Our service to customers is equal in importance to our track record of slitting

performance. Custom slitting, by definition, demands attention to the customers' needs, specs, and at times, even their own unspoken production issues. Once the job is in-house, our highly experienced team focuses on every detail from in-take to quality assurance throughout the run to the final packaging, shipping, warehousing or drop shipping, etc.

The supply chain had slowed the flow of manufacturers' incoming projects, especially following COVID. While we saw our deliveries increase to 6-7 weeks due to COVID, we are back to our standard of 4 weeks. Responding to customers' crises when they arise, Metlon helps with a faster turn-around whenever possible.

Current trends in this industry, as well as others, address new technology and the

lightning-paced advancement of generative artificial intelligence (AI). While AI may contribute to the customers' manufacturing processes, Metlon's completely in-house operation "is entirely hands-on every step of the way," notes Wayne Etechells, president.

"It has always been about helping customers to solve issues and to make their products work better," according to Etechells. Partnering with customers more deeply is another measure of its leadership, beyond their routine practice of meeting or exceeding customers' specifications.



PRECISION SLITTING & REWINDING SERVICES

Solutions For Your Business
...Plus our engineering help on your project



133 Frances Ave. Cranston, RI 02910
converting@metlon.com • metlon.com

PRECISION TOLERANCES: Down to +/- 0.001" or 0.025mm
SPECIALIZING IN NARROW WIDTH SLITTING:
Widths as narrow as 0.008" or 0.2mm
COILS, TRAVERSE, AND SPECIAL PUT - UPS
401-467-3435

End-To-End Solutions From Maxcess Keep You Running Better, Faster, Smarter

Maxcess® saves you time and money by optimizing your peak output performance. We do this by leveraging the world's best web handling product brands of **RotoMetrics, Fife, Tidland, MAGPOWR, Webex, Valley Roller** and **Componex**, offering customized end-to-end web handling solutions that help you work better, faster and smarter.

We manufacture all of our components to meet the highest standard of precision, with the deep application web side knowledge behind how each component works better together, to solve challenges faster across your converting line. All to provide unmatched product integration and precise positioning from unwind to rewind.

We're Maxcess. Solutions that help you work better, faster and smarter.

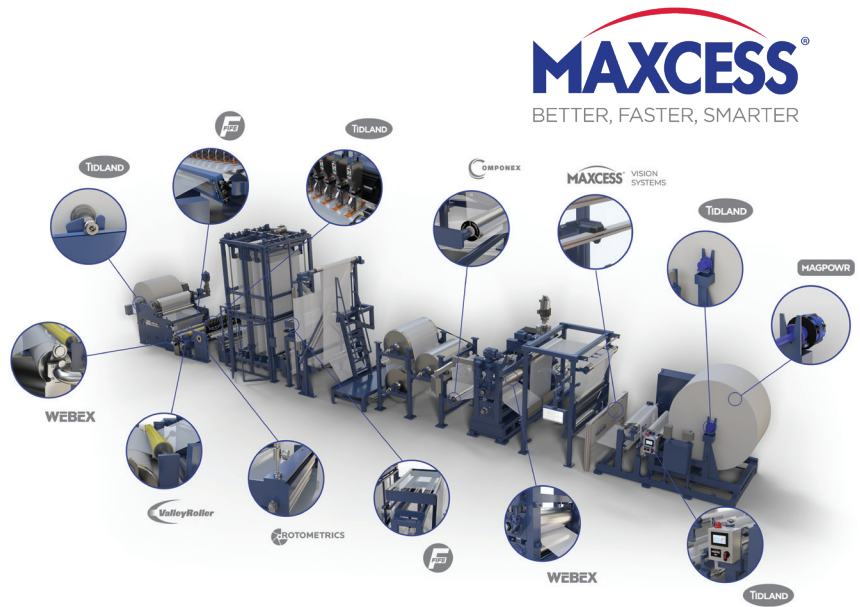

We Help You Run Better

Better Quality End Products are Achieved Through Components Designed to Work Better Together

- It Takes a Combination of Proper Tension Control, Guiding, Precision Rolls, Slitting, Winding and Cutting to Achieve Precise and Perfect Parts
- We Don't Point Fingers When Problems Occur. We Solve Problems Faster!
- Maxcess is the ONLY Company with End-to-End Knowledge and Support in All the Places You Do Business

Better Product Quality Means Less Scrap, Less Waste and Less Downtime

We Help You Run Faster

Increase Your Throughput and Reduce Downtime

- Decades of Combined Knowledge to Increase Line Speed
- Combining our Cutting Dies, Guiding and Tension Solutions, Precision Rolls, Shafts and Custom Performance Coatings Optimize Your Production Output While Keeping Downtime At A Minimum.

More Product Faster Means Greater Profits and More Opportunities

We Help You Run Smarter

Deep Global R&D Investments for Next-Generation Industry 4.0 Solutions

- Millions Invested Annually in Global R&D
- Industry 4.0 Smart Connected Devices
- Developing Inner-connected Data Analytics From The Entire Line, End-to-End, Allowing For:
 - Predictive Maintenance
 - Web Performance Monitoring
 - Wear Detection Inspection
 - Automated Manufacturing to Minimize Potential for Human Error



When You Run Smarter, You Run More Profitably

Call Us Today At **1-844-MAXCESS** or Visit Us At **maxcess.com**
To Learn How To Run Better, Faster and Smarter



	American Roller CO 48 www.americanroller.com
	Baldwin Technology Company, Inc. 27 www.baldwinvisionsystems.com
	Blower Application Co 4 www.bloapco.com
	Boschert LLC 10 www.boschertllc.com
	Catbridge Machinery 5 www.catbridge.com
	Chase Machine & Engineering 20 www.chasemachine.com
	Connecticut Metal Industries 46 www.ctmetal.com
	Diversified Enterprises 7 www.dynesonline.com
	Dover Flexo Electronics 28, 29 www.dfe.com
	ETI Converting Equipment 30, 31 www.eticonverting.com
	Flexographic Technical Assoc 25 www.flexography.org
	Global Plastics Inc 24 www.ripperonline.com
	Hudson-Sharp 32, 33 www.hudsonsharp.com
	IMS TECHNOLOGIES S.p.A 34, 35 www.imstechnologies.com
	ISRA Vision AG 36, 37 www.isravision.com/en/
	Jemmco LLC 15, 17 www.jemmco.com

	Lotar Enterprises 45, 46 www.lotarenterprises.com
	Meech International (USA) 13 www.meech.com
	Metlon Corp 44 metlon.com/custom-slitting-converting/
	New Era Converting Machinery FC www.neweraconverting.com
	Nordmeccanica Group 3 www.nordmeccanica.com
	Northcore Industries 14 www.northcoreind.com
	Paper Converting Machine 38, 39 www.pcmc.com
	Pinnacle Converting Equip Inc. 47 www.pinnacleconverting.com
	Powell Engineering Inc. 2 www.powellengineering.com
	Q C Electronics, Inc. 40, 41 www.qcelectronics.com
	Roll-2-Roll Technologies LLC 42, 43 www.r2r-tech.com
	Schober USA Inc 23 www.schoberusa.com
	Sonic Solutions 11 www.sonicolutionsusa.com
	Supply 55, Inc 46 www.supply55.com
	Takk Industries Inc 21 www.takk.com
	TLMI - Tag & Label Manufacturers I 19 www.tlmi.com
	Westech Converting 46 www.westech-industries.net

CONVERTING SIMPLIFIED

NEPATA CONVERTING EQUIPMENT



- Rewinders
- Slitters
- Coreless Rewinders
- Converting Centers
- Sheeters

Call or Email Supply 55, Inc. Today:
734-668-0755 / sales@supply55.com

WE BUY ALUMINUM FOIL

EV FOIL SCRAP • POLYFOIL SCRAP • BARE FOIL SCRAP

We Also Buy Surplus Rolls

CONNECTICUT METAL INDUSTRIES
(203) 736-0790 • sales@foil2.com
www.ctmetal.com

High Quality, On Time Converting

- Expert slitting, sheeting, trimming, die cutting, corona treatment & shrink wrapping services
- Quick turnaround on specialty projects
- Clean, affordable & reliable



Get A Quote Today:
www.Westech-Industries.net
800-916-9488

Surface Tension Testing

For Adhesion AND Cleanliness Testing



- Quick • Easy • Clean

LOTAR ENTERPRISES
TESTING INKS & PENS

Tel: 920-465-6678
sales@lotarllc.com
www.lotarllc.com



pin·na·cle

/ˈpɪnək(ə)l/

noun

1. The most successful point; the culmination.
2. The leader in high productivity converting equipment.

WE DEFINE THE INDUSTRY

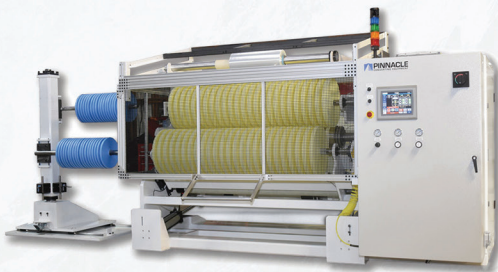

WE DESIGN AND BUILD CUSTOM CONVERTING EQUIPMENT TO MAXIMIZE YOUR PRODUCTIVITY

For over 28 years and with 1000s of machines in the field, Pinnacle Converting Equipment and Services has manufactured converting equipment and provided converting services for a wide variety of industries.



**MADE
IN THE USA**

11325-A NATIONS FORD ROAD
CHARLOTTE, NC 28134 | 704-376-3855



PFFC
An RDG Media, Inc. Publication
P.O. Box 529
Estero, FL 33929

Presorted Std
US Postage
PAID
RDG Media, Inc.

ARE YOU READY TO OPTIMIZE OUTPUT AND INCREASE YOUR ROLL DURABILITY?

- ✓ Boost your Production Lines
- ✓ Reduce Buildup & Scrap
- ✓ Better Control of your Process

DID YOU KNOW WE CAN COAT THIS?

From unique rollers to intricate parts, our team can coat them all! You may be surprised at the versatility and value Plasma Coatings can bring to your manufacturing process.

Before Coating



During Coating



After Coating



American Roller

Demand a Solution, Not a Product.

262.878.8665 | www.americanroller.com | info@americanroller.com